

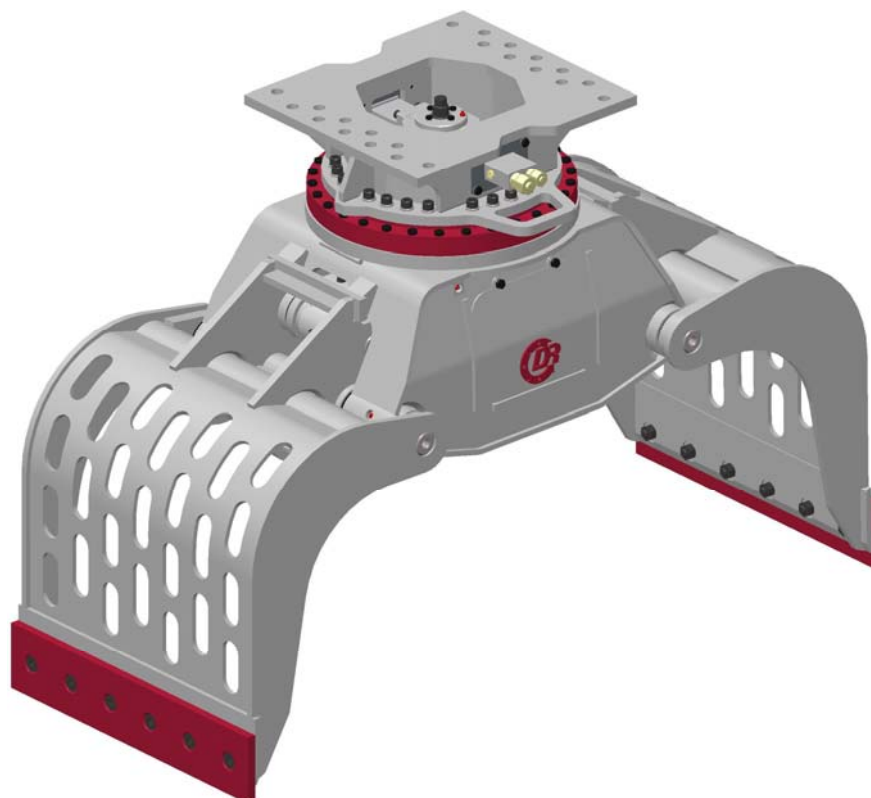

**Partsbook**  
for  
**Sorting Grab**  
**DRG-14 / D15HD**

Product	Part Number	Ref.
DRG-14 / D15HD	D15HD075ABA5	



Partsbook\_d15hd075aba5-a.docx

July 2015

**Demarec** Demolition and Recycling Equipment BV

Den Hoek 10, 5845 EL St. Anthonis, Netherlands

TEL.  
FAX

+31 (0) 485 442300  
+31 (0) 485 442120

INTERNET  
E-MAIL

[www.demarec.com](http://www.demarec.com)  
[info@demarec.com](mailto:info@demarec.com)

# Sorting Grab

## Grapple GP

Page	1	of	12
Date	July 2015		
Product type	DRG-14 / D15HD		
Number	D15HD075ABA5-A		

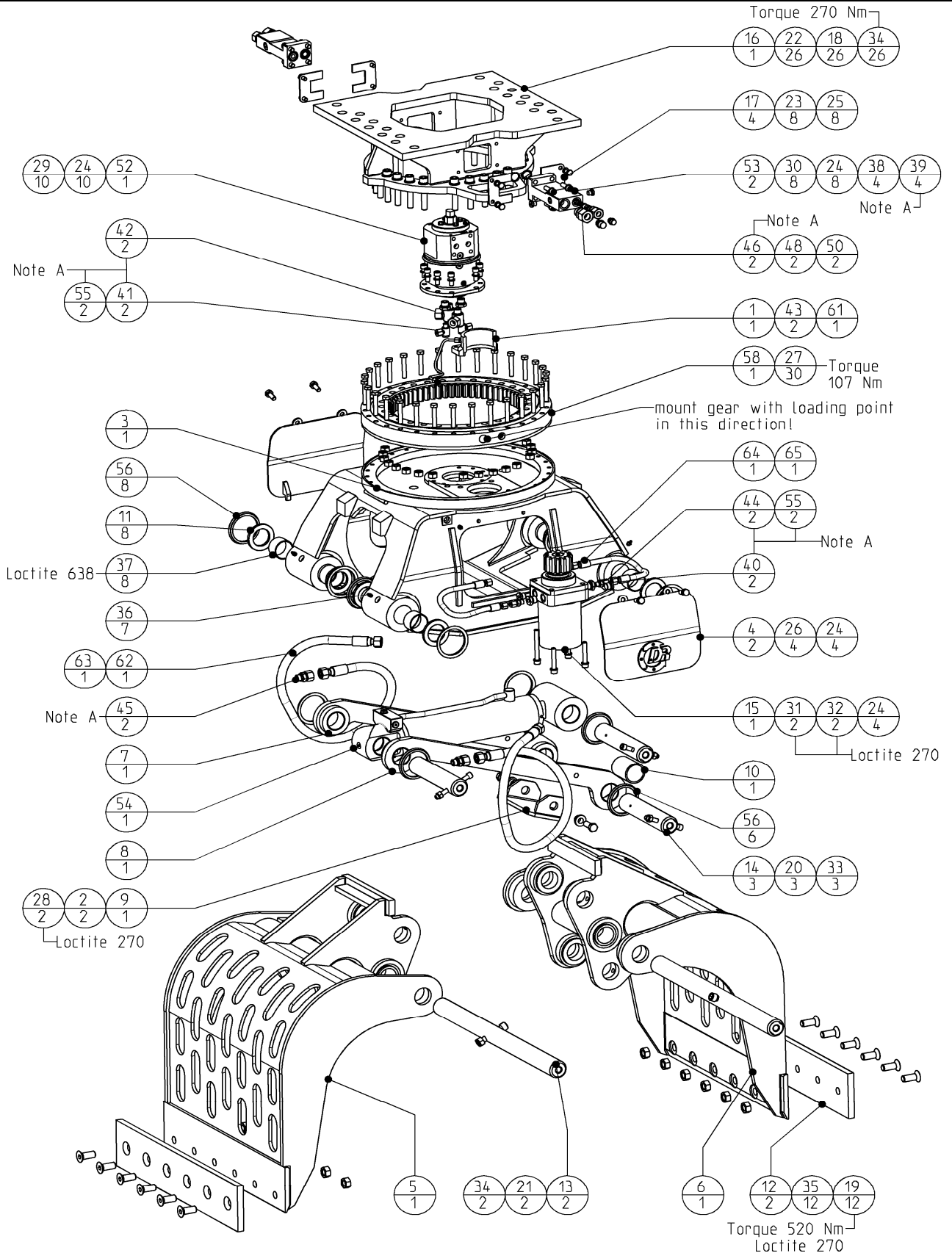

Parts marked with a letter in column "Set" can be ordered as a set with Itemnumber

Set	Wearpartset	Itemnumber
a	1 piece cutting edge set	402802

Note A  
Mount with Cyberbound TT62 according instructions at the end of this partsbook.

# Sorting Grab

Page	2	of	12
Date	July 2015		
Product type	DRG-14 / D15HD		
Number	D15HD075ABA5-A		

## Grapple GP

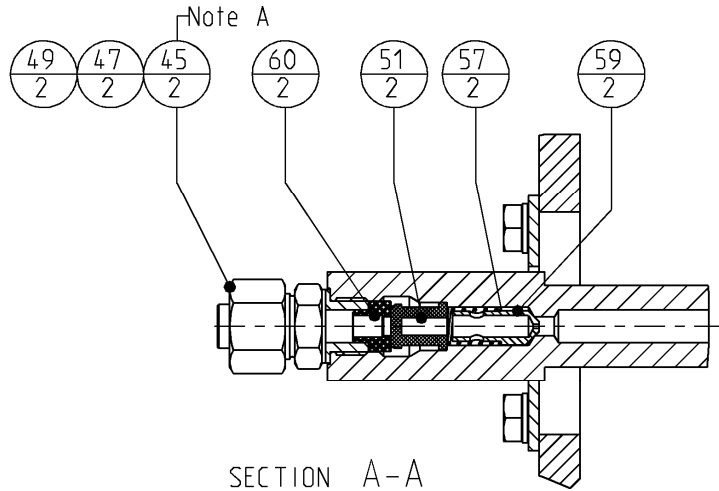

SECTION A-A  
SCALE 1:2

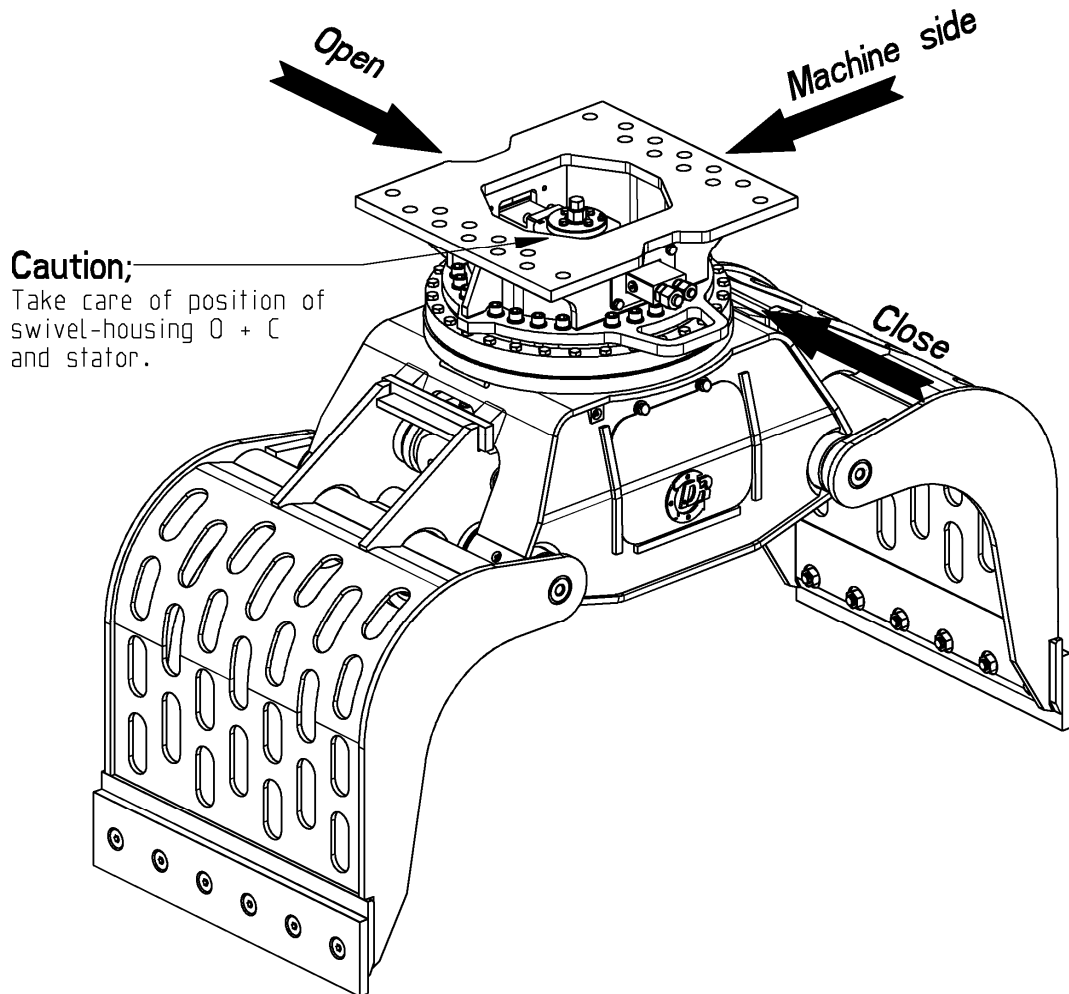

Sorting Grab	Page	3	of	12
	Date	July 2015		
	Product type	DRG-14 / D15HD		
Grapple GP	Number	D15HD075ABA5-A		

						a	35	500372	00	Flat countersunk head cap screws	12
							34	500266	00	Hex. socket head cap screw	28
							33	500257	00	Hex. socket head cap screw	3
							32	500256	00	Hex. socket head cap screw	2
							31	500253	00	Hex. socket head cap screw	2
	65	505002_VG02	01	Hydr. hose asm. 1/4"-SAE 100 R2AT	1		30	500249	00	Hex. socket head cap screw	8
	64	505002_VG01	01	Hydr. hose asm. 1/4"-SAE 100 R2AT	1		29	500247	00	Hex. socket head cap screw	10
	63	500849_VG02	02	Hydr. hose asm. 1/2" SAE 100R10	1		28	500144	00	Bolts Hexagon	2
	62	500849_VG01	02	Hydr. hose asm. 1/2" SAE 100R10	1		27	500137	00	Bolts Hexagon	30
	61	296052005_RM-DRG14	A	Hydr. hose asm. 3/16" SAE 100R1AT	1		26	500131	00	Bolts Hexagon	4
	60	773058645	A	Drossel - ring	2		25	500116	00	Bolts Hexagon	8
	59	273059742	D	Cone - valve + restriction	2		24	500068	00	Washer spring	26
	58	168055476	C	Slewing Ring; Internal Gear	1		23	500067	00	Washer spring	8
	57	165050749	A	Spring	2		22	500054	00	Washer HV	26
	56	504000	00	Seal	14		21	500031	00	Nut Hexagon self-locking	2
	55	503506	01	Reducing adapter BSPP	4		20	500030	00	Nut Hexagon self-locking	3
	54	502435	02	Cylinder GP	1	a	19	500006	00	Nut Hexagon	12
	53	502021	03	Connection flange	2		18	500005	00	Nut Hexagon	26
	52	502002	08	Swivel GP	1		17	401846	02	Cover	4
	51	502000	00	Filter	2		16	401367	05	Intermediate topplate asm.	1
	50	500946	00	Blanking plug	2		15	401329	01	Motor GP	1
	49	500945	00	Blanking plug	2		14	401301	03	Pin	3
	48	500941	00	Nut coupling	2		13	401300	02	Pin	2
	47	500940	00	Nut coupling	2	a	12	401298	01	Bolt on cutting edge	2
	46	500694	01	Male stud coupling	2		11	401297	03	Spacer	8
	45	500693	01	Male stud coupling	4		10	401295	00	Spacer	1
	44	500691	01	Male stud coupling	2		9	401293	02	Linkage protection asm.	1
	43	500690	00	Male stud coupling	2		8	401290	03	Parallel-Linkage asm. RH	1
	42	500663	01	Banjo Coupling	2		7	401289	03	Parallel-Linkage asm. LH	1
	41	500661	01	Banjo Coupling	2		6	401274	05	Shell asm. LH machined	1
	40	500652	01	Blanking end	2		5	401272	05	Shell asm. RH machined	1
	39	500650	01	Blanking end	4		4	401265	01	Cover asm.	2
	38	500600	01	O-ring	4		3	401251	06	Housing asm. machined	1
	37	500582	00	Bushing	8		2	401215	00	Bushing	2
	36	500560	00	Grease - nipple	7		1	400063	02	Cap - Pinion	1
						<b>Set</b>	<b>POS</b>	<b>PARTNUMBER</b>	<b>REV</b>	<b>PARTNAME</b>	<b>QT</b>

<h1>Sorting Grab</h1>	Page	4	of	12
	Date	July 2015		
	Product type	DRG-14 / D15HD		
<h2>Cylinder GP</h2>	Number	502435-01		

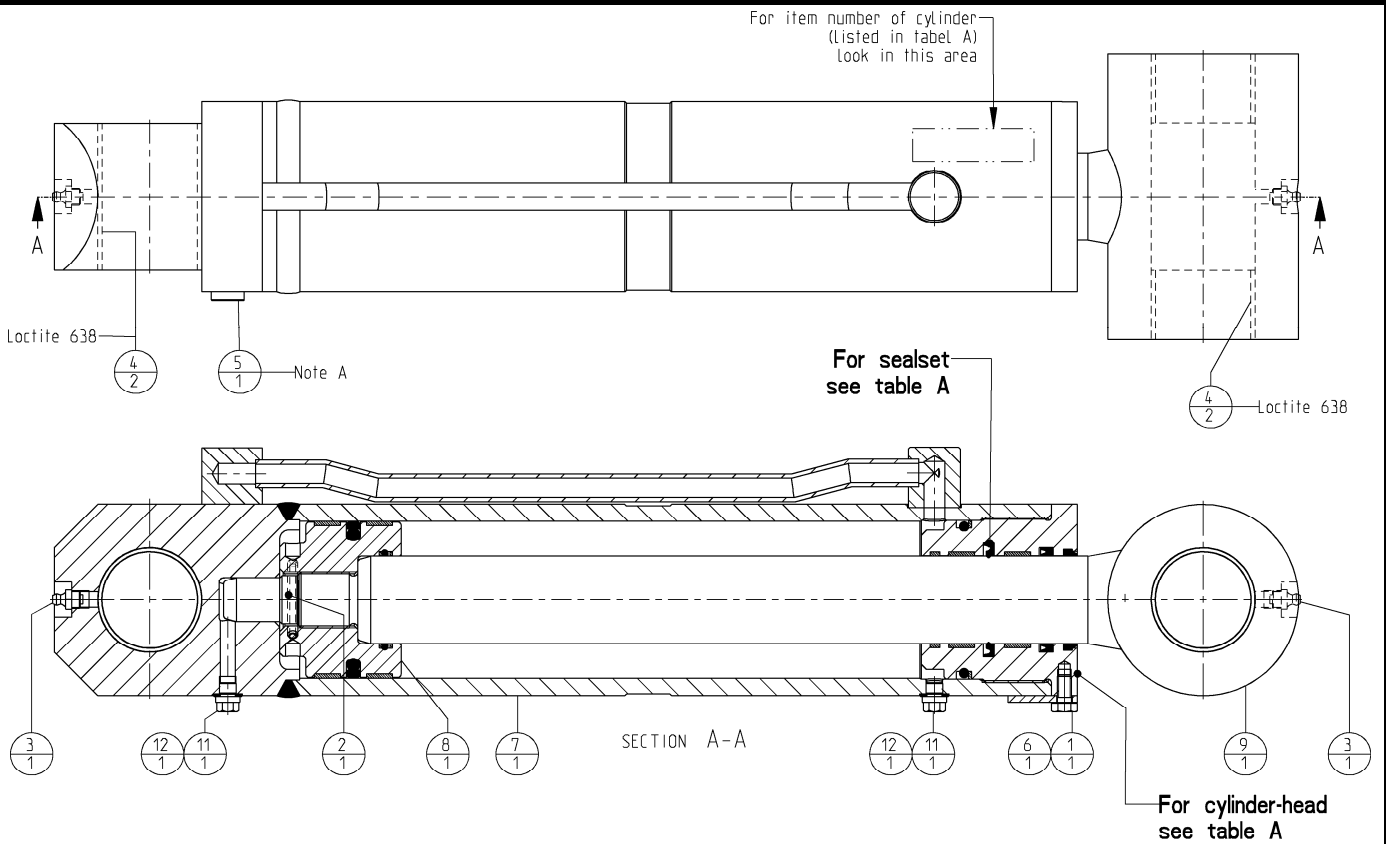

sealset and cylinderhead			
Item no. (on cylinder)	Sealset (service only)	Cylinder-head	Remark
502435 - 00 and up	504091	502436	
502010 - 00 and up	504091	502016	502436 replaces 502016

Note A  
Mount with Cyberbound TT62 according to instructions at the end of this partsbook.

table A

13	502437_RM502435	Sealset	1
12	504027	Seal	2
11	503513	Blanking screw	2
10	502436	Cylinder - head	1
9	502020	Cylinder - rod asm.	1
8	502017	Piston	1
7	502015	Cylinder - house asm.	1
6	500859	Lockplate	1
5	500650	Blanking end	1
4	500582	Bushing	4
3	500560	Grease - nipple	2
2	500521	Springtype straight pin	1
1	500102	Bolts Hexagon	1
<b>POS</b>	<b>PARTNUMBER</b>	<b>PARTNAME</b>	<b>QT</b>

Sorting Grab	Page	5	of	12
	Date	July 2015		
	Product type	DRG-14 / D15HD		
Sealset	Number	504093-01		

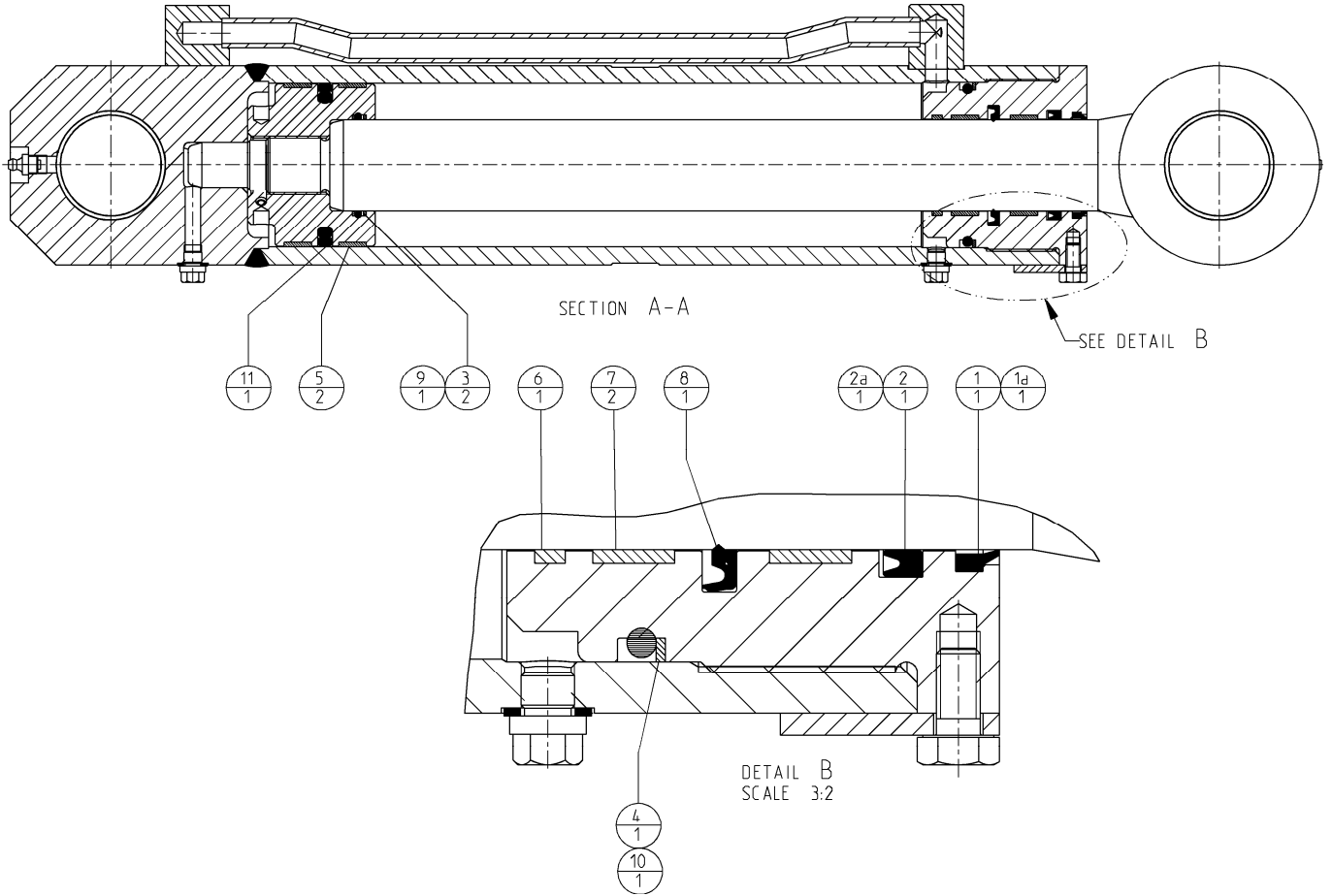

2a	RSK300500	Turcon Stepseal 2K	1
1a	UWRP505806	Scraper UWR-derivative	1
<b>POS</b>	<b>PARTNUMBER</b>	<b>PARTNAME</b>	<b>QT</b>
<b>Additional seals for service 504091 (includes 502437)</b>			
11	PT0400900	Turcon Glydring T	1
10	ORAR00338	O-ring	1
9	ORAR00226	O-ring	1
8	IBF50	Rod seal GP	1
7	GR73A0500	Bearing Luytex	2
6	GR6500500	Bearing Turcite	1
5	GP73A0900	Bearing Luytex	2
4	BU4300824	Back-up ring	1
3	BU2700500	Back-up ring	2
2	B35004P6000	U-Cup	1
1	504087	Scraper	1
<b>POS</b>	<b>PARTNUMBER</b>	<b>PARTNAME</b>	<b>QT</b>

<h1>Sorting Grab</h1>	Page	6	of	12
	Date	July 2015		
	Product type	DRG-14 / D15HD		
<h2>Swivel GP</h2>	Number	502002-08		

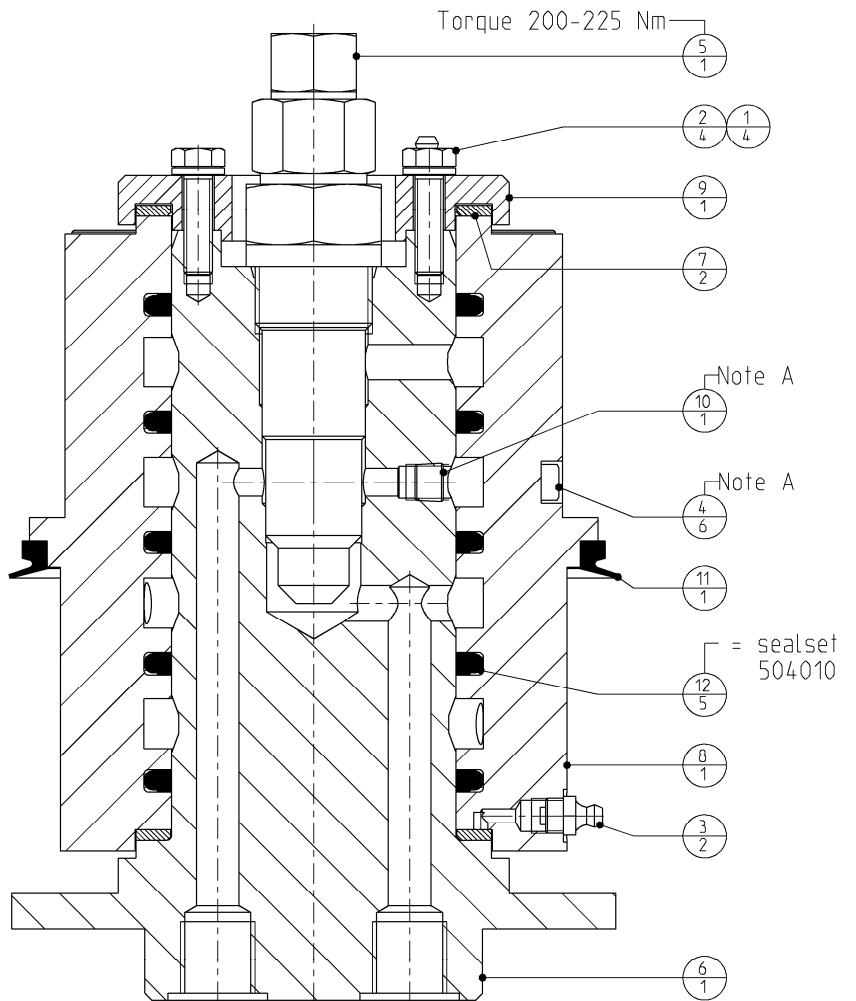
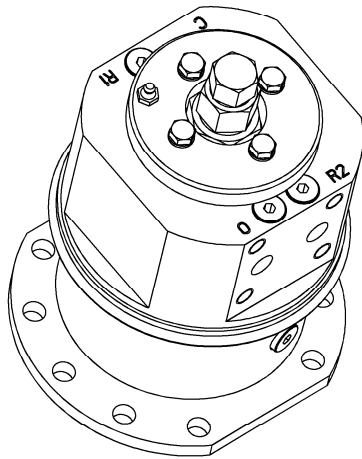
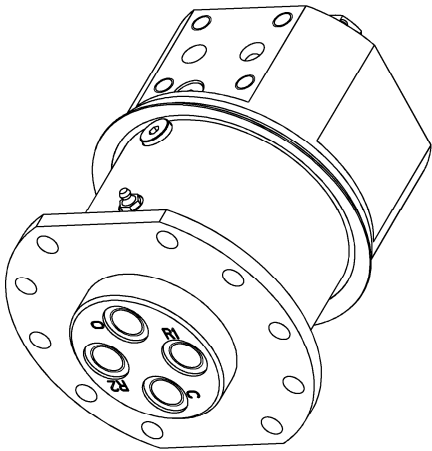

Note A  
Mount with Cyberbound TT62  
according instructions at the end  
of this partsbook.

12	504002	Seal - Roto Glyd Ring	5
11	504001	Seal	1
10	502123	Hex.socket plug-tapered	1
9	502008	Cover	1
8	502007	Housing rotator	1
7	502006	Axial ring	2
6	502003	Stator	1
5	500751	Overcentre valve	1
4	500650	Blanking end	6
3	500560	Grease - nipple	2
2	500105	Bolts Hexagon	4
1	500066	Washer spring	4
<b>POS</b>	<b>PARTNUMBER</b>	<b>PARTNAME</b>	<b>QT</b>

Sorting Grab	Page	7	of	12
	Date	July 2015		
	Product type	DRG-14 / D15HD		
Hydraulic motor GP	Number	401329-01		

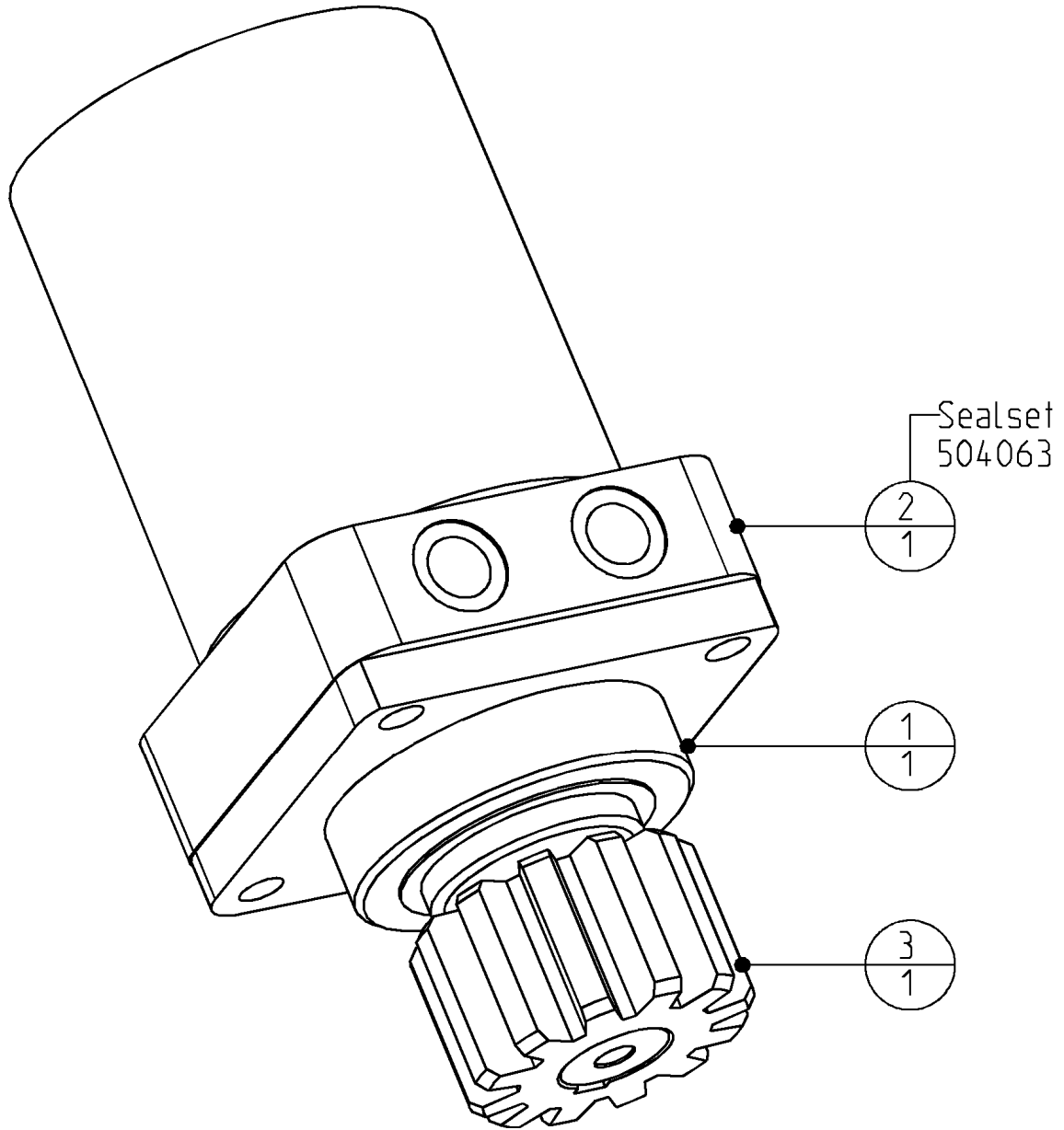

3	500854	Pinion	1
2	500764	Hydro-motor (Modified)	1
1	400593	Motor-flange	1
<b>POS</b>	<b>PARTNUMBER</b>	<b>PARTNAME</b>	<b>QT</b>



Sorting Grab	Page	8	of	12
	Date	July 2015		
	Product type	DRG-14 / D15HD		
Slewing ring	Number	168055476-C		

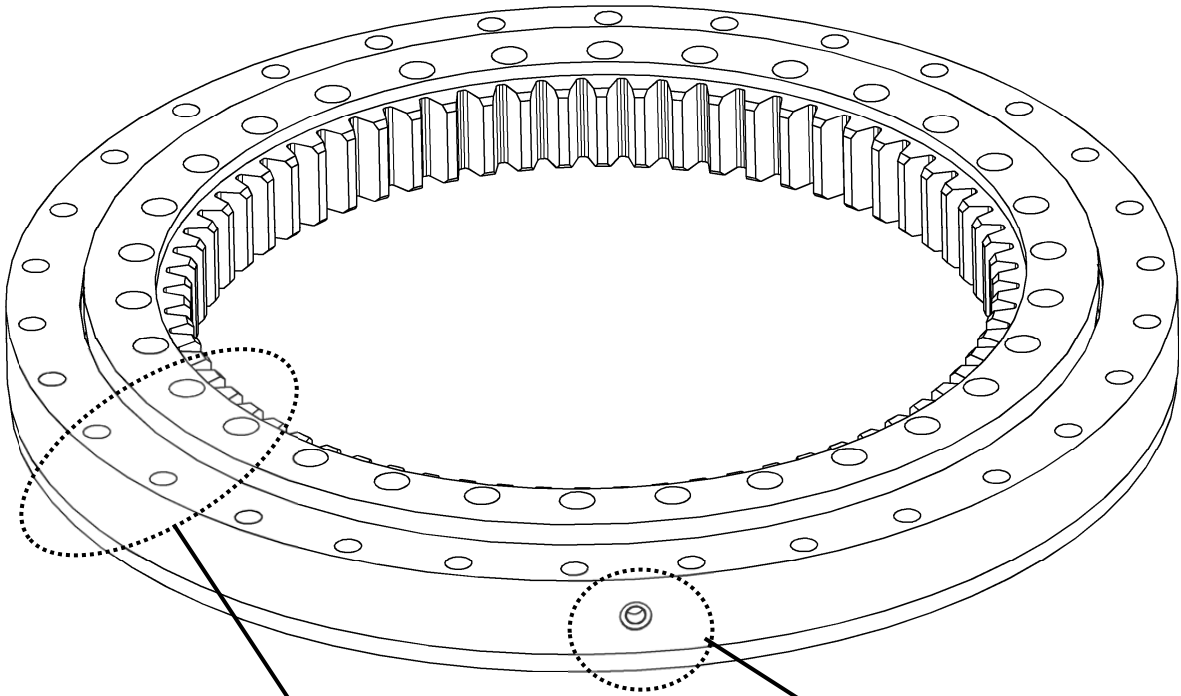

**2x grease nipple  
500560**

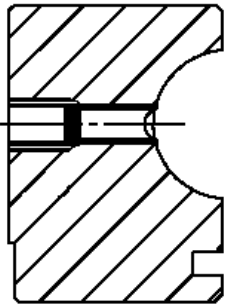

**2x seal 256060901  
mount with Loctite 480**

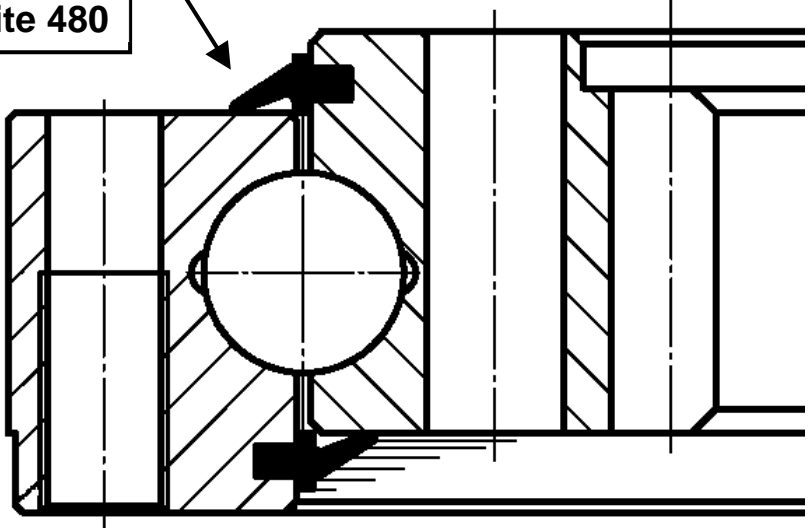

Sorting Grab	Page	9	of	12
	Date	July 2015		
	Product type	DRG-14 / D15HD		
Parallel linkage LH	Number	401289-03		

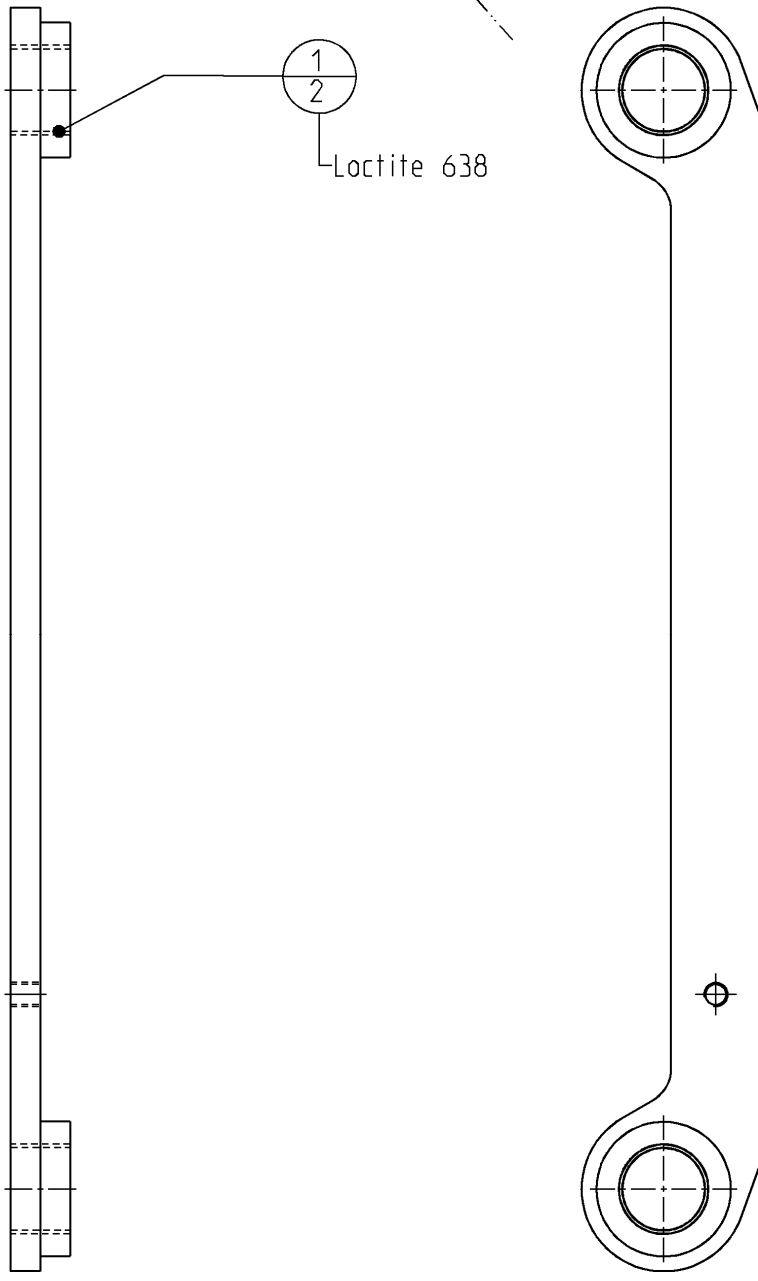

1	500582	Bushing	2
<b>POS</b>	<b>PARTNUMBER</b>	<b>PARTNAME</b>	<b>QT</b>

Sorting Grab	<i>Page</i>	10	<i>of</i>	12
	<i>Date</i>	July 2015		
	<i>Product type</i>	DRG-14 / D15HD		
Parallel linkage RH	<i>Number</i>	401290-03		

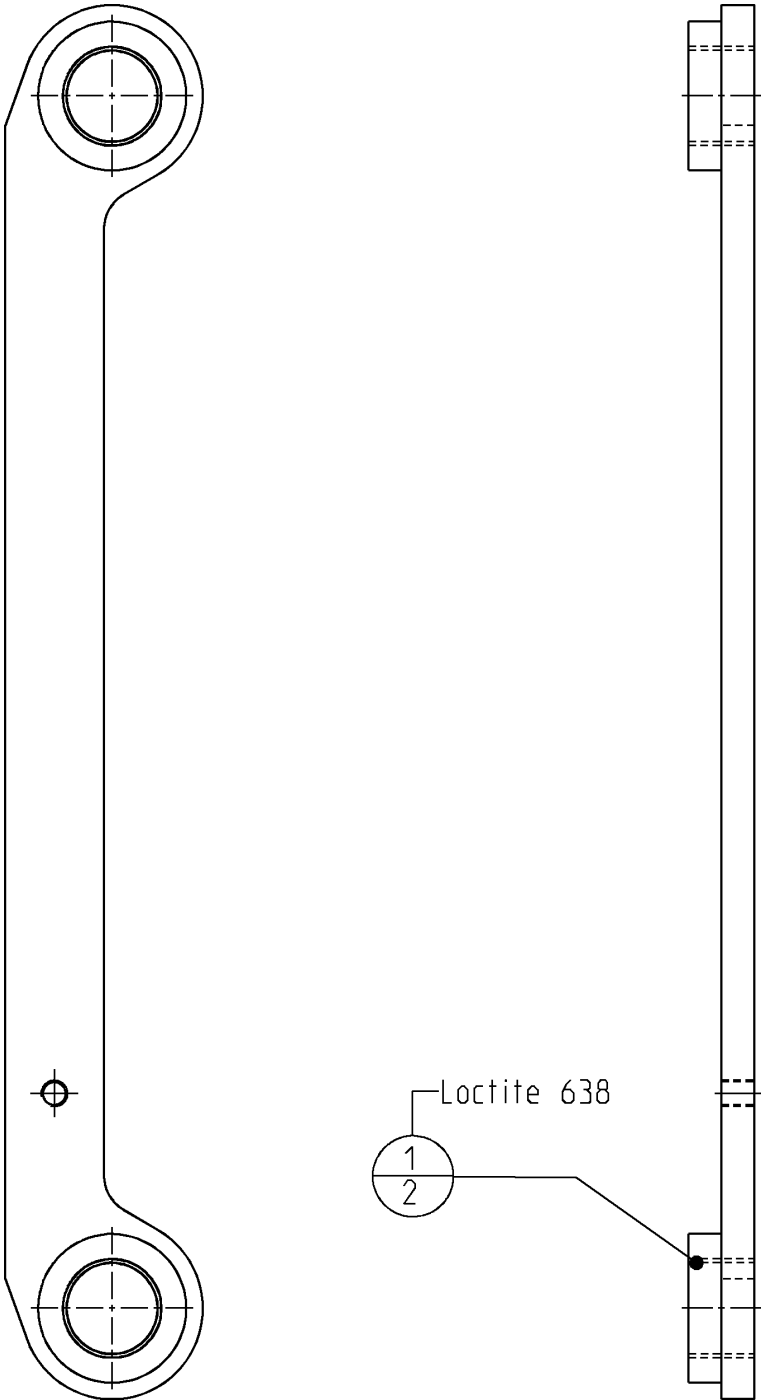

1	500582	Bushing	2
<b>POS</b>	<b>PARTNUMBER</b>	<b>PARTNAME</b>	<b>QT</b>

Sorting Grab	<i>Page</i>	11	<i>of</i>	12
	<i>Date</i>	July 2015		
	<i>Product type</i>	DRG-14 / D15HD		
Additional parts	<i>Number</i>	n.a.		

## Chemical lock

195050158	Cyberbond TT62 Pumpgel	1
506018	Loctite 480 Flacon 20 gr	1
506017	Loctite 638 Flacon 50 ml	1
506016	Loctite 270 Flacon 50 ml	1
<b>PARTNUMBER</b>	<b>PARTNAME</b>	<b>QT</b>

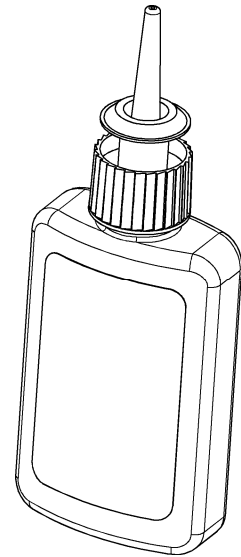

<b>Sorting Grab</b>	<i>Page</i>	12	of	12
	<i>Date</i>	July 2015		
	<i>Product type</i>	DRG-14 / D15HD		
<b>Instructions</b>	<i>Number</i>	n.a.		

## Mounting instructions for Cyberbound TT 62

This instruction shall guarantee that all hydraulic fittings and cartridges will be mounted and glued in correctly.

### Procedure:

Clean and degrease thoroughly all components with a special cleaner for anaerobic adhesives (e.g. Loctite cleaner 7063) or acetone.

Apply on the outside thread only a bead of Cyberbond TT62 pump gel to approx. 2/3 of the girth of the second thread for fittings up to a diameter of 20mm or to the entire girth for fittings with a diameter larger than 20mm.



Cyberbound  
TT 62



Clean from adhesive residues pressed out from the bore hole after fitting.

**ATTENTION. The sealings shall be free of adhesive residues!**

Tighten fittings with given fastening torques.

## Standard torque values for bolts (when not indicated)

Thread size	Torque (Nm) for quality		
	<b>8.8</b>	<b>10.9</b>	<b>12.9</b>
<b>M8</b>	22,5	32,4	38,7
<b>M10</b>	45,0	63,0	75,6
<b>M12</b>	77,4	109,0	131,0
<b>M16</b>	194,0	270,0	324,0
<b>M20</b>	369,0	522,0	630,0
<b>M24</b>	639,0	900,0	1080,0
<b>M27</b>	945,0	1305,0	1575,0
<b>M30</b>	1260,0	1800,0	2160,0



## DEMAREC AND KINSHOFER WORLDWIDE

---

### Netherlands:

#### **Demarec**

Demolition and Recycling Equipment BV

Den Hoek 10

5845 EL St. Anthonis

Netherlands

TEL. +31 (0) 485 442300

FAX +31 (0) 485 442120

Email:

info@demarec.com

### United Kingdom:

#### **Kinshofer UK Ltd.**

4 Milton Industrial Court,

Horsfield Way, Bredbury

Stockport, Cheshire, SK6 2TA

United Kingdom

TEL. +44 (0) 161 - 406 7046

FAX +44 (0) 161 - 406 7014

Email:

sales@kinshofer.co.uk

### France:

#### **Kinshofer France S.A.R.L.**

B.P. 20100

67213 Obernai Cedex

France

TEL. +33 (0) 388 39 55 00

FAX +33 (0) 388 79 06 75

Email:

info@kinshofer.fr

### Czech Republic:

#### **Kinshofer CZ s.r.o.**

Cs. Legii 568

37810 Ceske Velenice

Czech Republic

TEL. +420 384 – 795 110

FAX +420 384 – 795 120

### Headquarters:

#### Germany:

**Kinshofer GmbH**

Hauptstrasse 76

83666 Waakirchen

Germany

TEL. +49 (0) 8021 – 88 99 0

FAX +49 (0) 8021 – 88 99 37

Email:

info@kinshofer.com

#### North America:

#### **Kinshofer North America**

5040 Mainway Drive, Unit 11

Burlington, ON L7L 7G5

Canada

TEL. +1 (905) 335 2856

FAX +1 (905) 335 4529

Toll Free in Canada and USA:

TEL. 1-800-268-9525

Email:

sales-northamerica@kinshofer.com

#### Finland:

#### **Kinshofer Aponox Oy**

Terminaalitie 10

13430 Hämeenlinna

Finland

TEL. +358 (0)75 7540 200

FAX +358 (0)75 7540 210

#### Beijing:

#### **Darda Kinshofer**

#### **Construction Machinery Co. Ltd.**

Unit #306, Landmark Tower 2

8 Dongsanhuan Road

Beijing 100004

China

TEL. +86 (10) 6590 6422

FAX +86 (10) 6590 6423

Email:

info@darda.com.cn