

Item	CPN	Ref	Qty		
10	86265048	26428	1	Inflating screw Vis de gonflage	Fuellschraube Tornillo de inflado
20	86241403	14826	1	Ring Bague BS	Ring Anillo
30	86279627	36306	16	Plastic plug Bouchon plastique	Plastikstopfen Tapón de plástico
40	86223203	89495	16	UNF 3/4", socket head screw Vis CHc UNF3/4"	Skt. Schraube UNF 3/4" Tornillo CHc UNF 3/4"
50	86265147	26600	1	Upper flange Flasque supérieur	Obere Flansch Disco superior
60	86248283	17639	1	Diaphragm Membrane	Membrane Membrana
70	86258019	22847	1	Lower flange Flasque inférieur	Untere Flansch Disco inferior
• 80	86249810	18652	1	Nylon ring Bague nylon	Ring Anillo Nylon
• 90	86275559	33616	1	O'ring Joint torique	O'ring Junta tórica
100	86254661	21292	1	Threaded plug Bouchon fileté	Stopfen Roscado tapón
• 110	86230711	6711	1	O'ring Joint torique	O'ring Junta tórica
120	86314952	56047	1	Knee piece 1"1/4 NPTF Genouillère 1"1/4 NPTF	Schwenkanschluß 1"1/4 NPTF Rótula 1"1/4 NPTF
• 130	86228970	5346	2	O'ring Joint torique	O'ring Junta tórica
140	86419603	18406	1	Threaded plug Bouchon fileté	Stopfen Roscado tapón

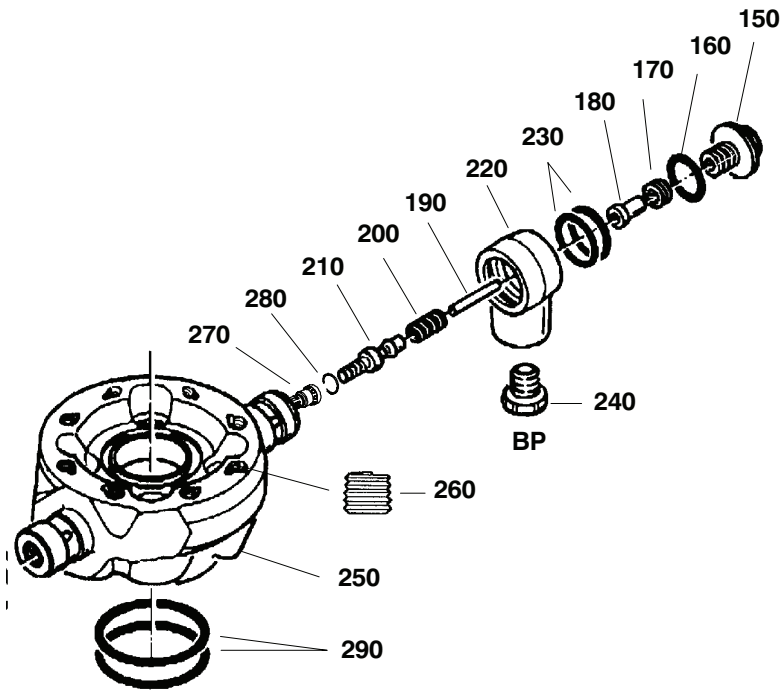

150	86254661	21292	1	Threaded plug Bouchon fileté	Stopfen Roscado tapón
• 160	86230711	6711	1	O'ring Joint torique	O'ring Junta tórica
170	86254653	21291	12	Shim Rondelle de calage	Beilegscheibe Arandela de calado
180	86254646	21290	1	Barrel Canon	Federsitz Corredera
190	86254638	21289	1	Spring guide Guide ressort	Federführung Guía resorte
200	86248887	18083	1	Spring Ressort	Feder Resorte
210	86258233	22975	1	Slide "C" Tiroir "C"	Regulierstift "C" Corredera "C"
220	86314952	56047	1	Knee piece 1"1/4 NPTF Genouillère 1"1/4 NPTF	Schwenkanschluß 1"1/4 NPTF Rótula 1"1/4 NPTF
• 230	86228970	5346	2	O'ring Joint torique	O'ring Junta tórica
240	86419603	18406	1	Threaded plug Bouchon fileté	Stopfen Roscado tapón
250	86309853	53221	1	Back head including : Tête arrière comprenant :	Kopfteil, best. aus : Cabeza trasera comprende :
260	86256005	21910	8	(Helicoil thread UNF 1" (Filet rapporté UNF 1"	(Gewindeinsatz UNF 1" (Rosca helicoïdal UNF 1"
270	86254612	21287	1	(Liner (Chemise de tiroir	(Liner (Camisa de válvula
280	86264546	26145	1	(Snap ring (Jonc	(Sprengring (Junco
• 290	86280286	36579	2	O'ring Joint torique	O'ring Junta tórica

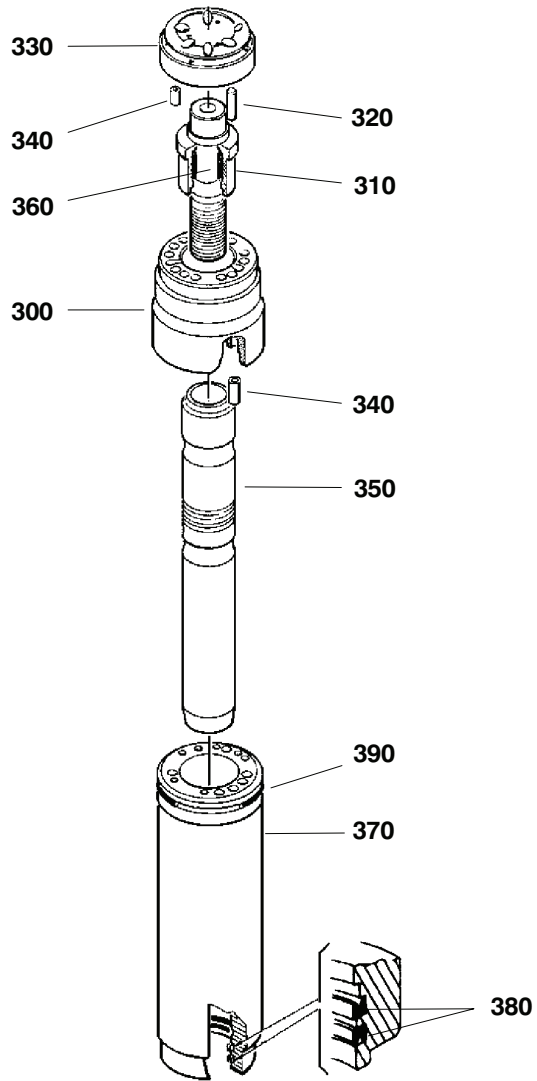

Item	CPN	Ref	Qty		
300	86251816	19708	1	Distribution box Boîte de distribution	Schiebergehäuse Caja de distribución
310	86248440	17678	1	Distributor Distributeur	Steuerschieber Distribuidor
320	86258381	23062	3	Piston Piston	Ventilkolben Pistòn
330	86258373	23061	1	Distribution cover Couvercle de distribution	Steuerdeckel Tapa de distribución
340	86252020	19867	2	Centering ring Bague de centrage	Zentrierstift Anillo
350	86251790	19704	1	Piston "C" Piston "C"	Schlagkolben "C" Pistòn "C"
360	86250925	19170	1	Plunger "C" Plongeur "C"	Plunger "C" Vástago "C"
370	86267689	28362	1	Cylinder Cylindre	Zylinder Cilindro
• 380	86251741	19698	2	Lip seal Joint à lèvres	Lippendichtung Junta de labios
• 390	86495520	93616	1	O'ring Joint torique	O'ring Junta tórica



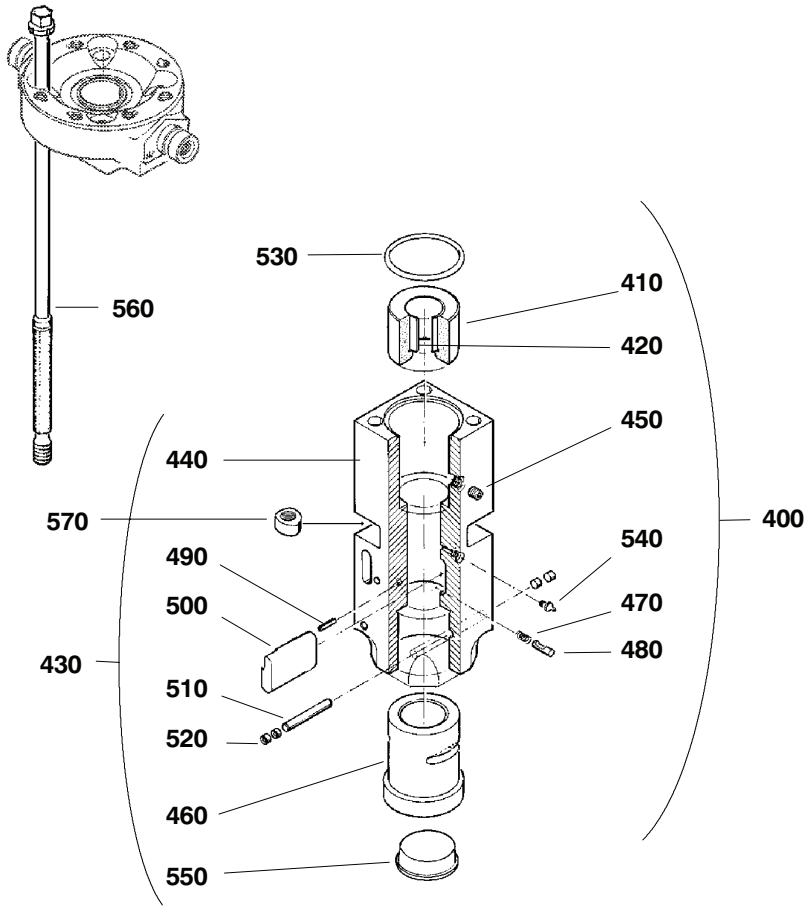

400	86267978	28432	1	Front guide + spacer including : Guide avant + entretoise comprenant :	Vorderzylinder + Zwischenstück, mit : Fondo + entretecho que comprende :
410	86259579	23830	1	- Spacer including : - Entretoise comprenant :	- Zwischenstück, mit : - Entretecho que comprende :
420	86257169	22448	1	(Ring (Bague	(Ring (Anillo
430	86267986	28433	1	- Complete front guide including : - Guide avant complet comprenant :	- kpl. Vorderzylinder, mit : - Fondo que comprende :
440	86268802	29209	1	(Front guide including : (Guide avant comprenant :	(Vorderzylinder, mit : (Fondo que comprende :
450	86492063	95283	1	(Threaded plug (Bouchon fileté	(Stopfen (Roscado tapón
460	86253853	20944	1	(Chuck bushing (Douille	(Meißelhülse (Manguito
470	86257714	22681	2	(Spring (Ressort	(Feder (Resorte
480	86261260	24824	2	(Lock (Verrou	(Riegel (Cerrojo
490	86231305	7046	2	(Elastic pin (Goupille élastique	(Zyl.-Stift (Eje liso
500	86264454 86603743		2	(Retaining pin (Clavette de retenue	(Haltekeil (Placa de retención
510	86253861	20948	1	(Pin (Axe lisse	(Zyl.-Stift (Eje liso
520	86231362	7076	4	(Plug (Bouchon	(Stopfen (Tapón
• 530	86495520	93616	1	(O'ring (Joint torique	(O'ring (Junta tórica
540	86230059	6178	1	(Oiler (Graisseur	(Schmiernippel (Engrasador
550	86345964	69796	1	(Plastic plug (Bouchon plastique	(Plastikstopfen (Tapón de plástico
560	86318599	57891	4	Assembling bolt Vis d'assemblage	Zuganker Tornillo de unión
570	86317435	57369	4	Nut Ecrou	Mutter Tuerca
•	86412053	89860	1	SEAL PACKAGE POCHETTE RECHANGE	DICHTUNGSSATZ BOLSA DE RECAMBIO