

# Parts book

Product type
MQP-45-S Serie 5



Den Hoek 10  
5845 EL St. Anthonis  
the Netherlands  
Telephone +31 (0)485 442300  
Fax +31 (0)485 442120

[info@demarec.com](mailto:info@demarec.com)  
[www.demarec.com](http://www.demarec.com)



*Copyright Demolition and Recycling Equipment BV  
All rights strictly reserved.  
Reproductions to third parties in any form whatever is not permitted  
without written authority from the proprietor*

Partsbook\_404085-00.doc

# Multi Quick Processor

## Jaw Group

Page	1	of	2
Date	April 2009		
Product type	MQP-45-S		
Number	MQP45S390DAA 404085-00		

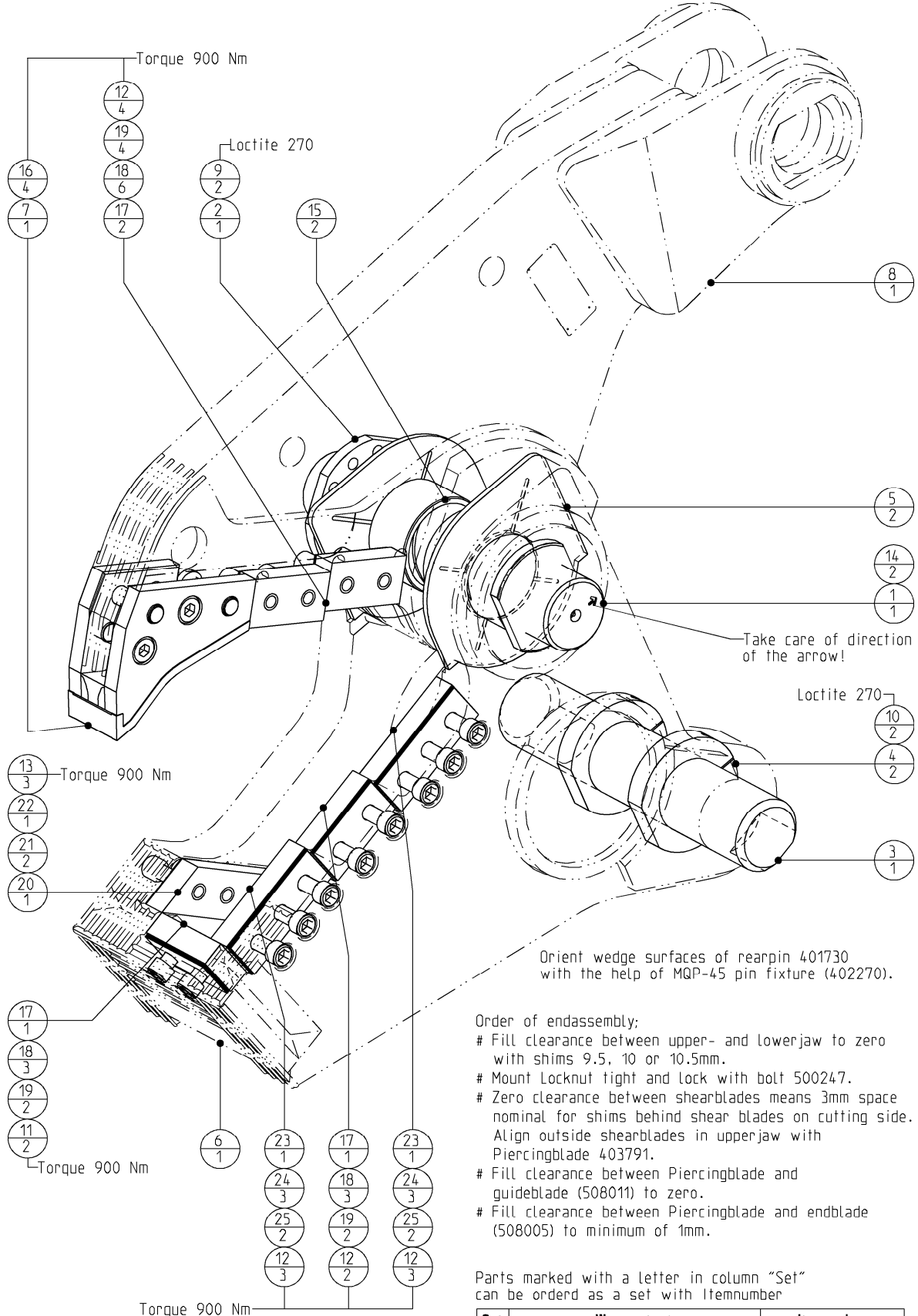

- Order of endassembly;
- # Fill clearance between upper- and lowerjaw to zero with shims 9.5, 10 or 10.5mm.
  - # Mount Locknut tight and lock with bolt 500247.
  - # Zero clearance between shearblades means 3mm space nominal for shims behind shear blades on cutting side. Align outside shearblades in upperjaw with Piercingblade 403791.
  - # Fill clearance between Piercingblade and guideblade (508011) to zero.
  - # Fill clearance between Piercingblade and endblade (508005) to minimum of 1mm.

Parts marked with a letter in column "Set" can be ordered as a set with Itemnumber

Set	Wearpartset	Itemnumber
a	Cuttingedges set	402833
b	Piercing- tip / shroud set	403655

<b>Multi Quick Processor</b>	<i>Page</i>	<b>2</b>	<i>of</i>	<b>2</b>
	<i>Date</i>	<b>April 2009</b>		
	<i>Product type</i>	<b>MQP-45-S</b>		
<b>Jaw Group</b>	<i>Number</i>	<b>MQP45S390DAA 404085-00</b>		

a	25	508022	Shim - straight	4
a	24	508021	Shim - straight	6
a	23	508020	Shear - blade straight	2
a	22	508013	Shim - diamond	1
a	21	508012	Shim - diamond	2
a	20	508011	Shear - blade diamond	1
a	19	508007	Shim - straight	8
a	18	508006	Shim - straight	12
a	17	508005	Shear - blade straight	4
b	16	506023	Shoulder bolt	4
	15	500573	Bushing	2
	14	500560	Grease - nipple	2
a	13	500286	Hex. socket head cap screw	3
a	12	500285	Hex. socket head cap screw	12
a	11	500282	Hex. socket head cap screw	2
	10	500262	Hex. socket head cap screw	2
	9	500247	Hex. socket head cap screw	2
	8	404086	Jaw - upper asm. machined	1
b	7	403954	Piercingblade asm.	1
	6	402591	Jaw - lower asm. machined	1
	5	401920	Spacer	2
	4	401764	Ring - clamp	2
	3	401730	Pin	1
	2	401729	Locknut M130x4	1
	1	401728	Pin	1
<b>Set</b>	<b>POS</b>	<b>PARTNUMBER</b>	<b>PARTNAME</b>	<b>QT</b>