

Parts book

Product type
DRC-25 Serie 1



Den Hoek 10
5845 EL St. Anthonis
the Netherlands
Telephone +31 (0)485 442300
Fax +31 (0)485 442120

info@demarec.com
www.demarec.com



*Copyright Demolition and Recycling Equipment BV
All rights strictly reserved.
Reproductions to third parties in any form whatever is not permitted
without written authority from the proprietor*

Partsbook_404427-00.doc

Rotatable Combi Shear

Housing GP

Page	1	of	15
Date	March 2010		
Product type	DRC-25		
Number	DRC25H075AAA5 404427-00		

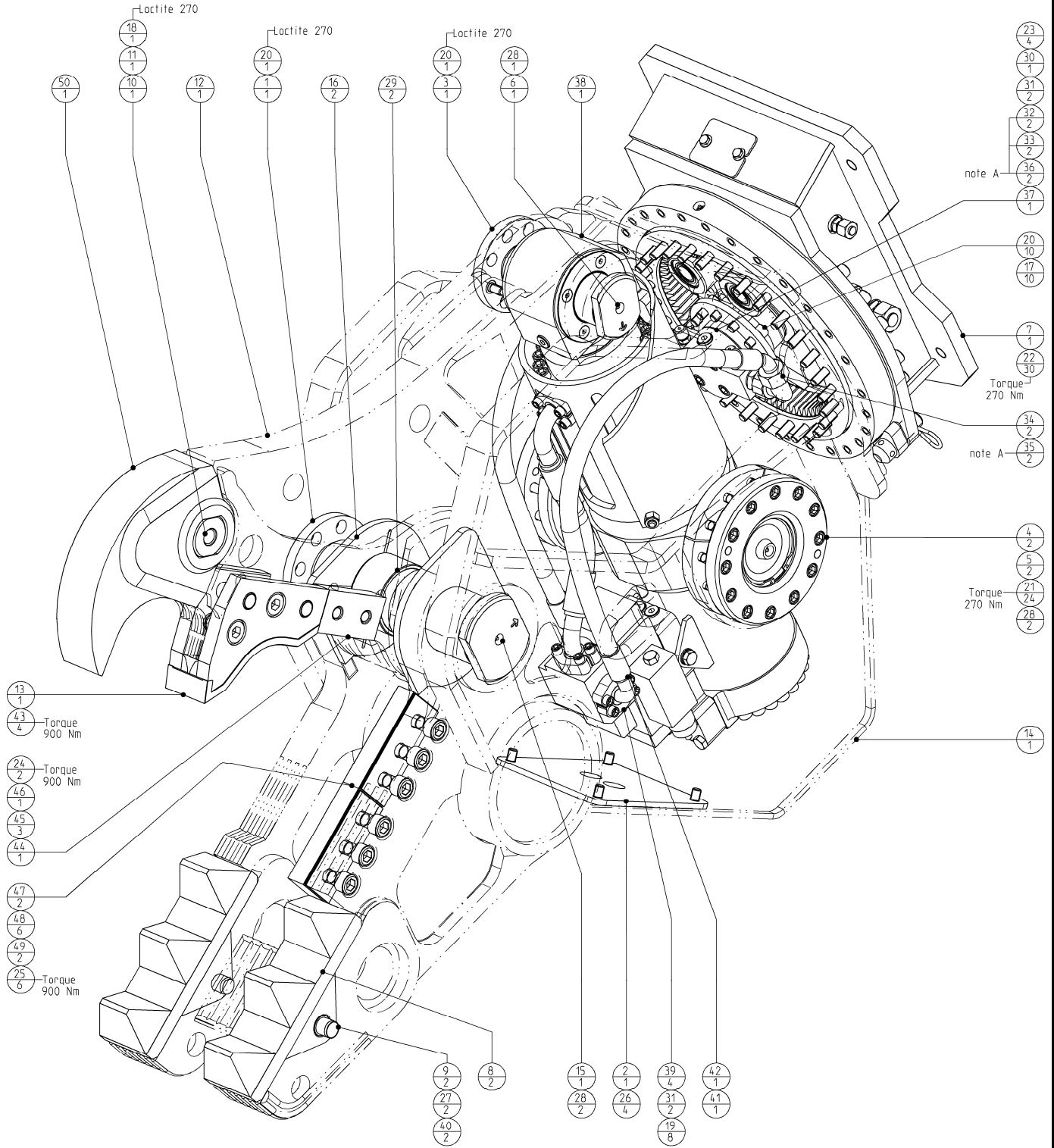

Parts marked with a letter in column "Set" can be ordered as a set with Itemnumber

Set	Wearpartset	Itemnumber
a	tripod shroud set	402843
b	Cuttingedges set	403655
c	Piercing-blade set	403653
d	Ripper-tooth set (excl. pin)	402846

note A

- # Degrease threads with brake cleaner.
- # Rub in- and outside threads in with Cyberbound TT62 by using a brush.
- # Clean seal from plug during screwing in.
- # A drying time from the glue of at least 1 hour needs to be respected before it has any contact with oil.

Rotatable Combi Shear	Page	2	of	15
	Date	March 2010		
	Product type	DRC-25		
Housing GP	Number	DRC25H075AAA5 404427-00		

						26	500358	Flat countersunk head cap screws	4
					b	25	500284	Hex. socket head cap screw	6
d	50	740057906	Ripper - tooth	1	b	24	500283	Hex. socket head cap screw	2
b	49	508022	Shim - straight	2		23	500268	Hex. socket head cap screw	4
b	48	508021	Shim - straight	6		22	500266	Hex. socket head cap screw	30
b	47	508020	Shear - blade straight	2		21	500265	Hex. socket head cap screw	24
b	46	508007	Shim - straight	1		20	500258	Hex. socket head cap screw	12
b	45	508006	Shim - straight	3		19	500250	Hex. socket head cap screw	8
b	44	508005	Shear - blade straight	1	d	18	500144	Bolts Hexagon	1
c	43	506022	Shoulder bolt	4		17	500069	Washer spring	10
	42	505058_RH_RM404427	Hydr. hose RH asm. 3/4" SAE 100R10	1		16	404459	Spacer	2
	41	505058_LH_RM404427	Hydr. hose LH asm. 3/4" SAE 100R10	1		15	404458	Pin	1
a	40	504053	O-ring	2		14	404428	Housing asm. machined	1
	39	503503	SAE split - flange	4	c	13	403804	Piercingblade asm.	1
	38	502470	Hydraulic Cylinder & Valve GP	1		12	403631	Jaw - upper asm. machined	1
	37	501073	Swivel - flange	1	d	11	403030	Lock - cover	1
	36	500740	Test-point	2	a	10	403029	Lock - pin	1
	35	500695	Male stud coupling	2	a	9	403023	Lock - pin	2
	34	500675	Adjustable male stud elbow	2		8	403022	Shroud - Tripod	2
	33	500653	Blanking end	2		7	402970	Rotatorhead GP (DDL-MQP)	1
	32	500652	Blanking end	2		6	402967	Pin	1
	31	500601	O-ring	4		5	402965	Ring	2
	30	500600	O-ring	1		4	402962	Bearing - housing GP	2
	29	500572	Bushing	2		3	401441	Locknut	1
	28	500560	Grease - nipple	5		2	401416	Cover	1
a	27	500559	Tension bush - outside	2	SET	1	401313	Locknut	1
					POS		PARTNUMBER	PARTNAME	QT

Rotatable Combi Shear

Page	3	of	15
Date	March 2010		
Product type	DRC-25		
Number	402970-07		

Rotatorhead GP

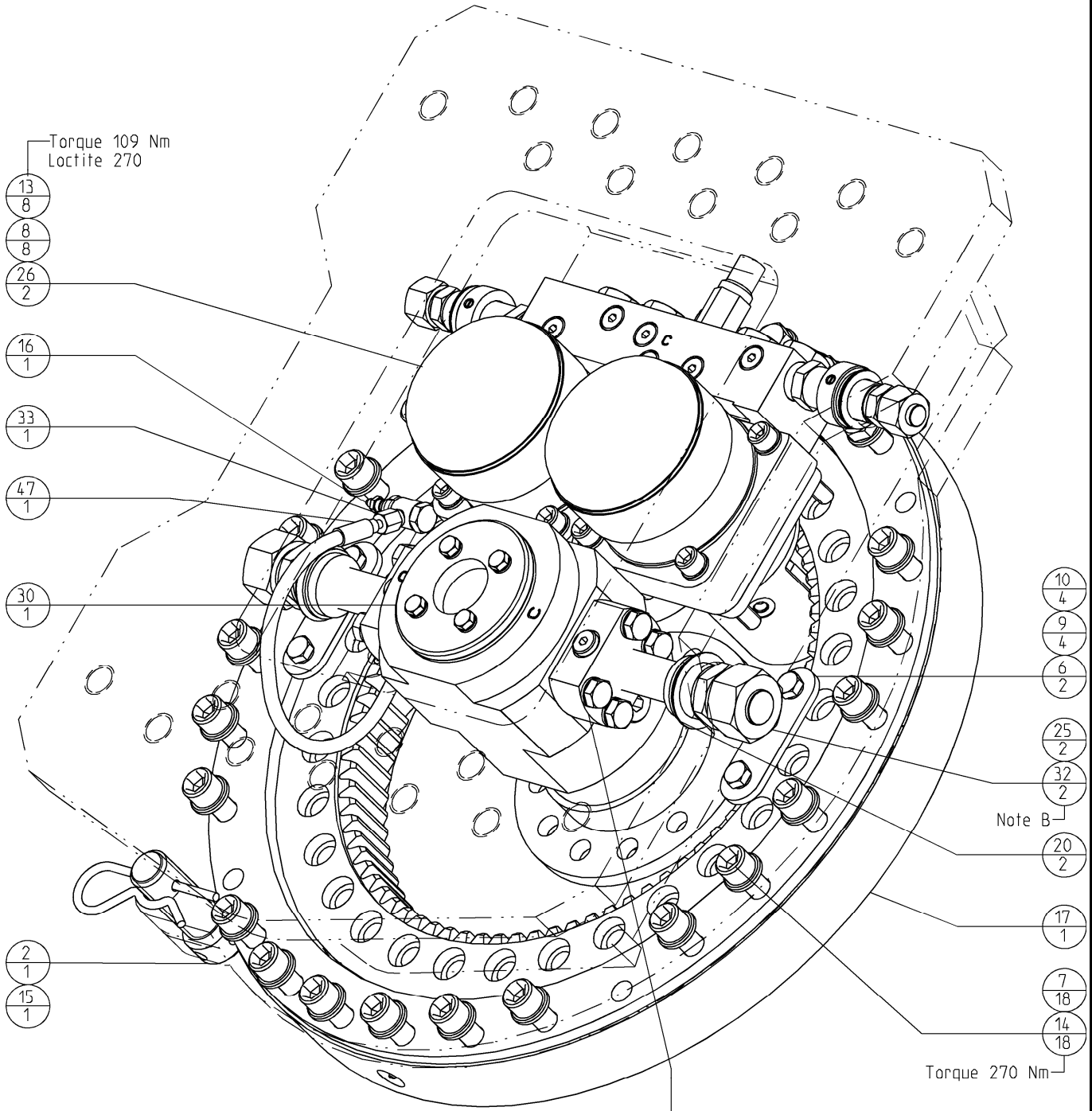

Note A
Grind coupling on inside of motor flange flat.

- Note B
- # Degrease threads with brake cleaner.
 - # Rub in- and outside threads in with Cyberbound TT62 by using a brush.
 - # Clean seal from plug during screwing in.
 - # A drying time from the glue of at least 1 hour needs to be respected before it has any contact with oil.

1	19	21	8	11
2	2	2	8	8

Note B

Rotatable Combi Shear	Page	4	of	15
	Date	March 2010		
	Product type	DRC-25		
Rotatorhead GP	Number	402970-07		

- 38
2
- 44
1

Replaces:
blanking end 503581

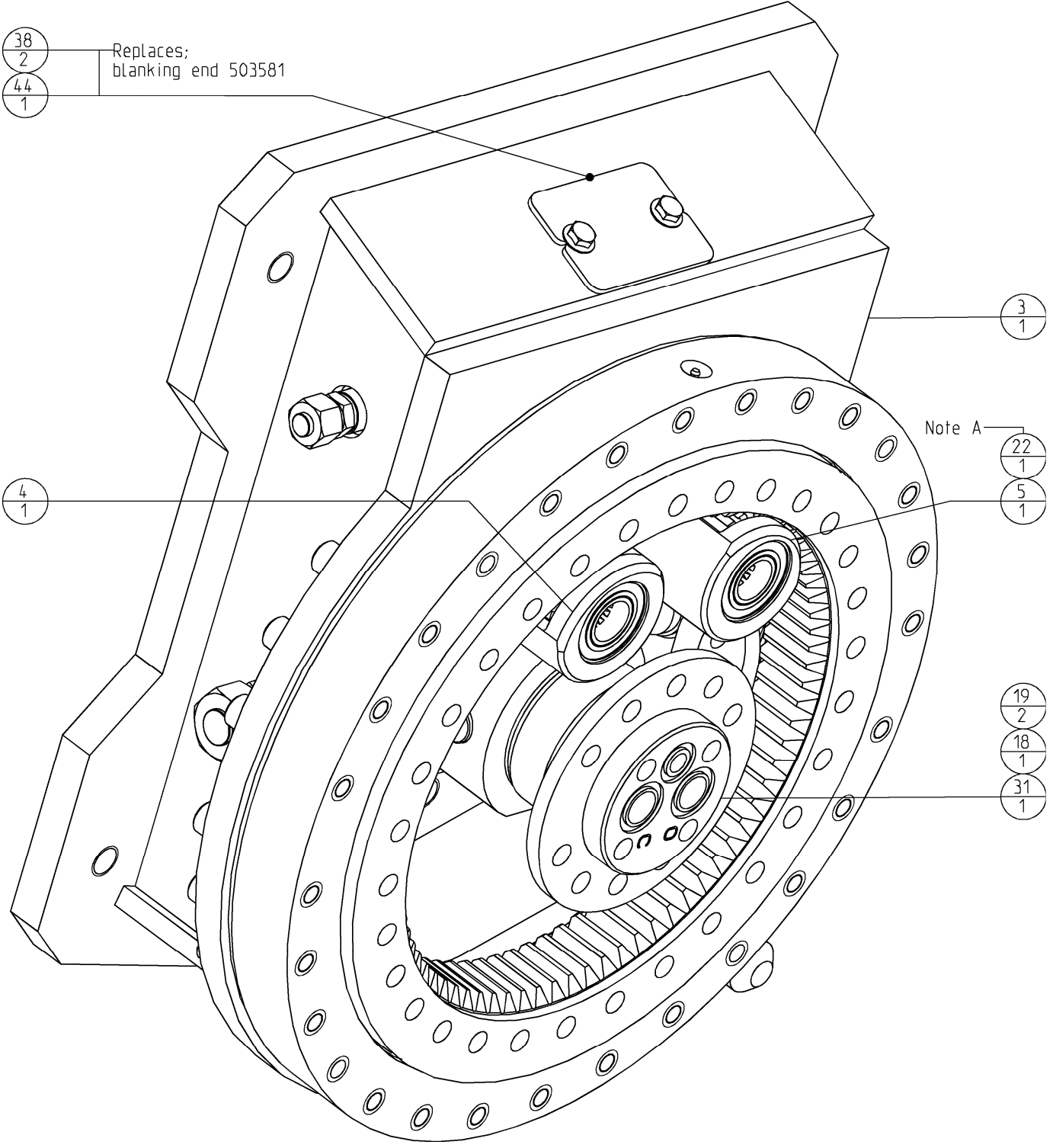

Rotatable Combi Shear

Page	5	of	15
Date	March 2010		
Product type	DRC-25		
Number	402970-07		

Rotatorhead GP

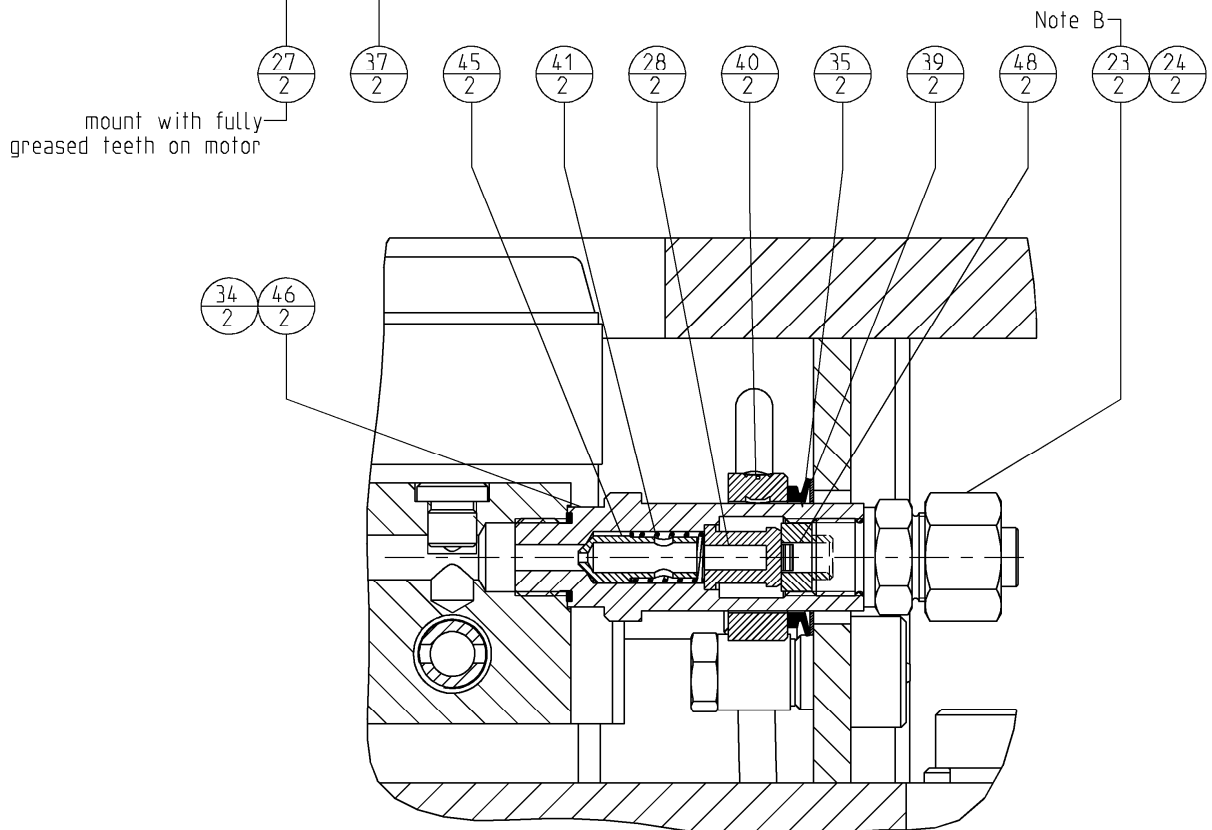
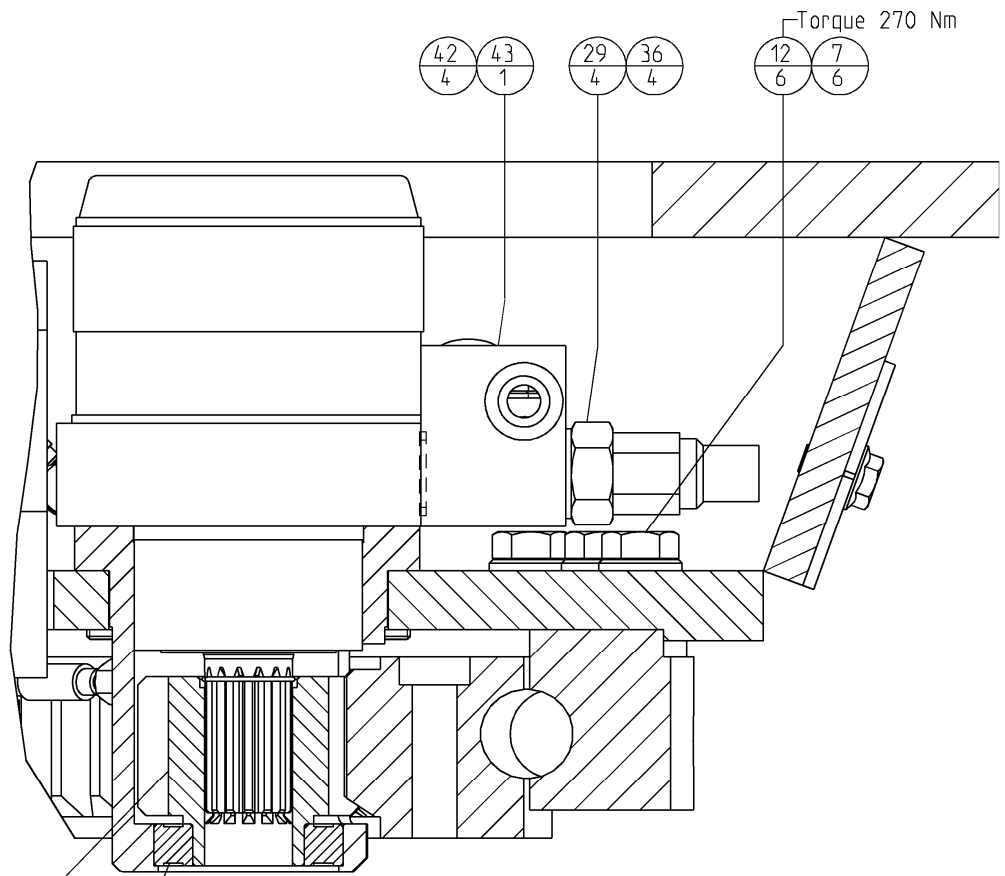

Rotatable Combi Shear	Page	6	of	15
	Date	March 2010		
	Product type	DRC-25		
Rotatorhead GP	Number	402970-07		

POS	PARTNUMBER	PARTNAME	QT	
	25	500947	Blanking plug	2
	24	500945	Blanking plug	2
48	773058645	Drossel - ring		2
47	296012594_VG02	Hydr. hose asm. 3/16" SAE 100R1AT		1
46	291058602	Sleeve G1/2"-G1/2"		2
45	273058601	Cone - valve + restriction		2
44	273013056	Cover		1
43	270057528	Valve GP		1
42	257057530	Quadseal		4
41	165050749	Spring		2
40	140000031	Ring - adjusting		2
39	122011550	Ring - shim		2
38	120013834	Bolts Hexagon - self locking		2
37	507002	Bearing - Ball		2
36	504081	Bonded seal		4
35	504068	Seal		2
34	504038	Seal G1/2'		2
33	503612	Banjo Coupling		1
32	503536	Male stud coupling		2
31	502330	Flange		1
30	502286	Swivel GP		1
29	502285	Banjo - bolt		4
28	502000	Filter		2
27	501058	Pinion		2
26	501057	Hydro - motor		2
	1	400214	Hydraulic flange - pipe	2
	2	400217	Lock-pin	1
	3	402971	Rotatorhead asm. machined	1
	4	402978	Motor flange & housing LH	1
	5	402979	Motor flange & housing RH	1
	6	402980	Cover	2
	7	500054	Washer HV	24
	8	500068	Washer spring	16
	9	500076	Washer spring	4
	10	500116	Bolts Hexagon	4
	11	500135	Bolts Hexagon	8
	12	500150	Bolts Hexagon	6
	13	500254	Hex. socket head cap screw	8
	14	500266	Hex. socket head cap screw	18
	15	500504-2	Locking pin (hair-pin)	1
	16	500560	Grease - nipple	1
	17	500590	Stewing Ring; Internal Gear	1
	18	500600	O-ring	1
	19	500601	O-ring	4
	20	500620	Seal	2
	21	500650	Blanking end	2
	22	500690	Male stud coupling	1
	23	500693	Male stud coupling	2

Rotatable Combi Shear

Page	7	of	15
Date	March 2010		
Product type	DRC-25		
Number	502470-01		

Cylinder & Valve GP

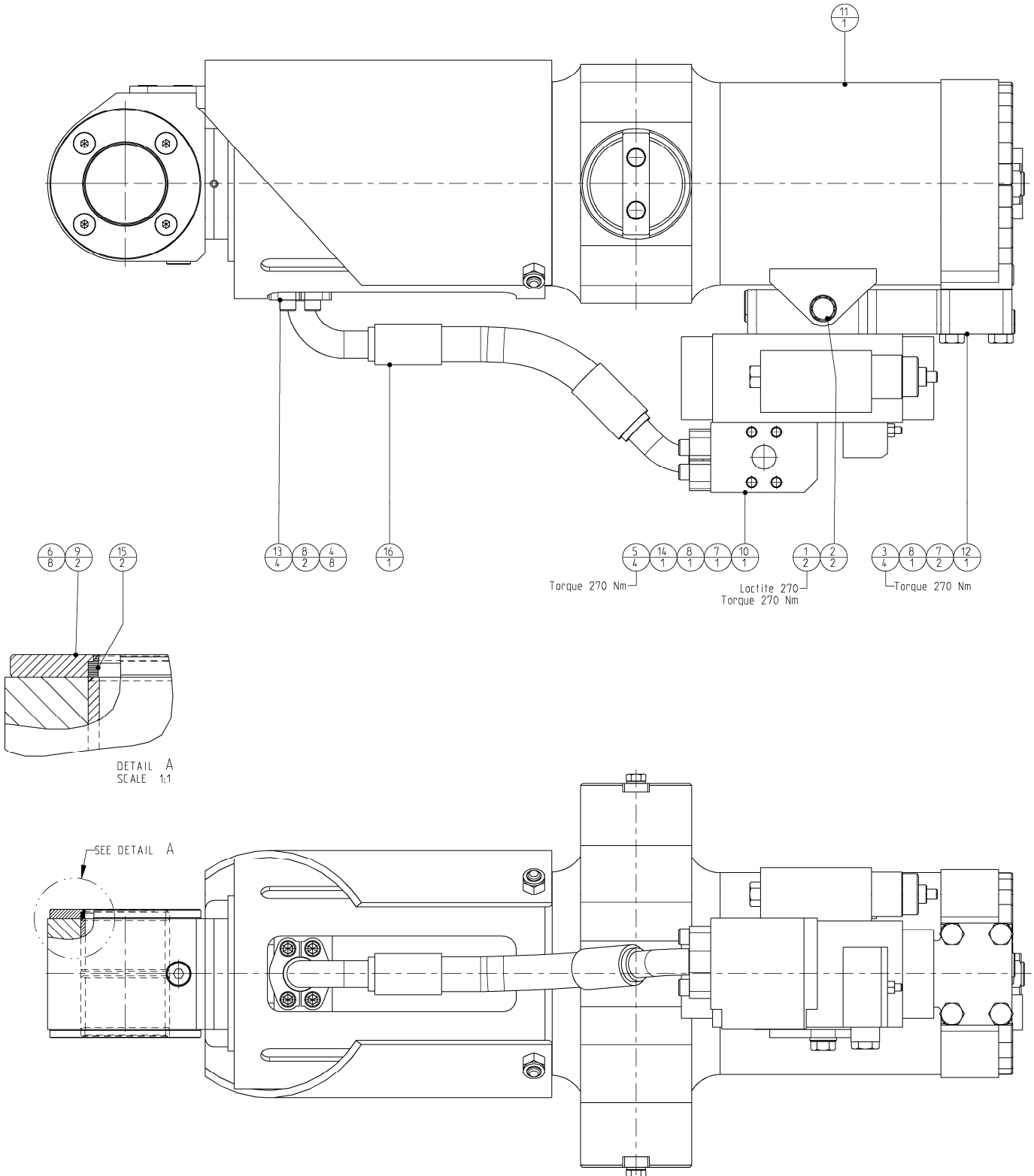

Rotatable Combi Shear	<i>Page</i>	8	<i>of</i>	15
	<i>Date</i>	March 2010		
	<i>Product type</i>	DRC-25		
Cylinder & Valve GP	<i>Number</i>	502470-01		

16	505053_VG502470	Hydr. hose asm. 1"SAE 100R13	1
15	504069	Scraper	2
14	504009	O-ring	1
13	503503	SAE split - flange	4
12	502478	Flange - bottom GP	1
11	502471	Hydraulic Cylinder GP	1
10	502322	Speedvalve	1
9	502308	Spacer	2
8	500601	O-ring	4
7	500600	O-ring	3
6	500347	Flat countersunk head cap screws	8
5	500263	Hex. socket head cap screw	4
4	500250	Hex. socket head cap screw	8
3	500149	Bolts Hexagon	4
2	500142	Bolts Hexagon	2
1	500054	Washer HV	2
POS	PARTNUMBER	PARTNAME	QT

Rotatable Combi Shear

Page	9	of	15
Date	March 2010		
Product type	DRC-25		
Number	502471-01		

Cylinder GP

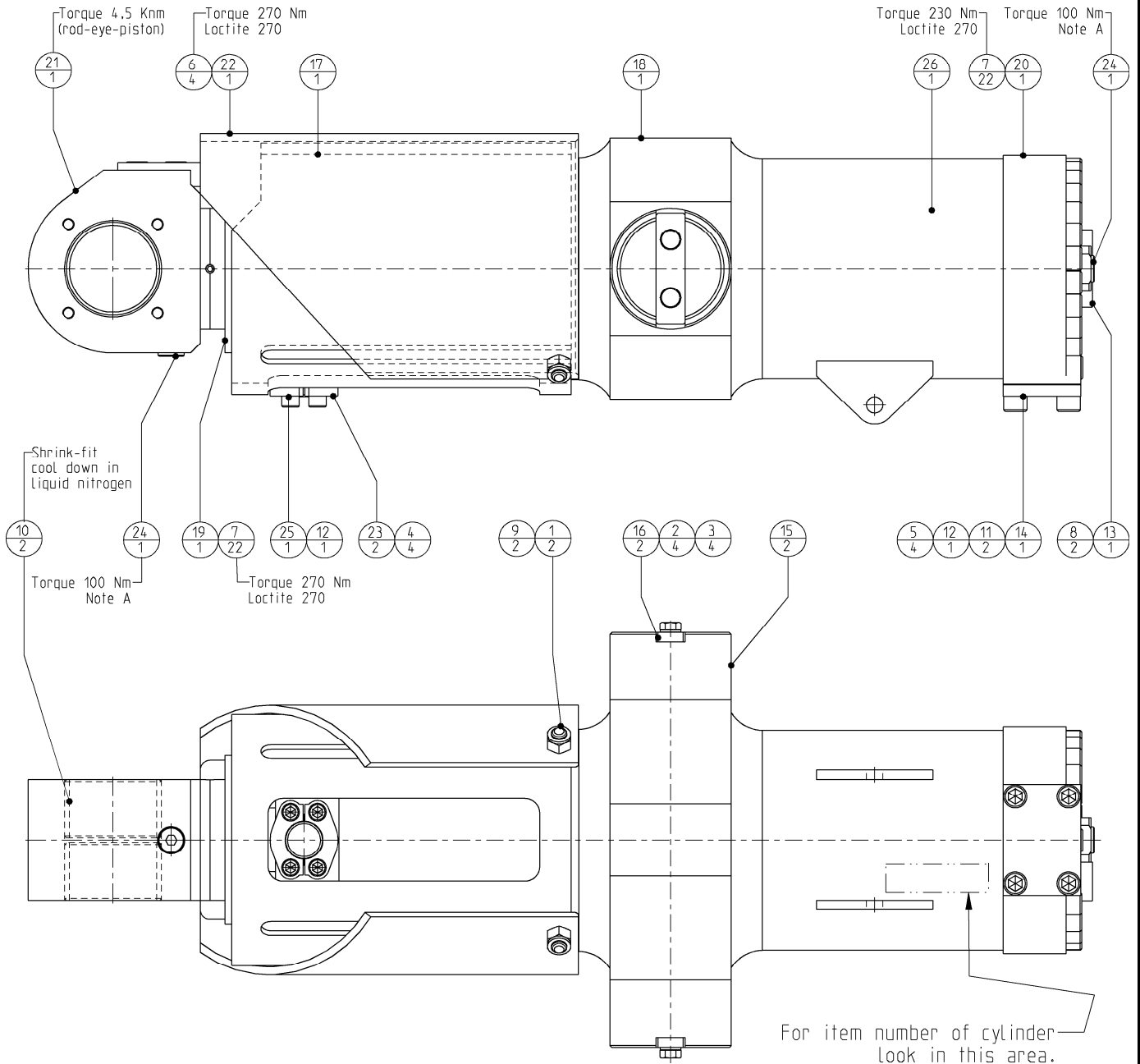

- Note A
- # Degrease threads with brake cleaner.
 - # Rub in- and outside threads in with Cyberbound TT62 by using a brush.
 - # Clean seal from plug during screwing in.
 - # A drying time from the glue of at least 1 hour needs to be respected before it has any contact with oil.

Rotatable Combi Shear	<i>Page</i>	10	<i>of</i>	15
	<i>Date</i>	March 2010		
	<i>Product type</i>	DRC-25		
Cylinder GP	<i>Number</i>	502471-01		

26	502344_RM502470	Seal - set	1
25	291057570	SAE stop	1
24	290058184	Blanking end ISO 6149	2
23	503503	SAE split - flange	2
22	502475	Protection cap asm.	1
21	502473	Rod GP	1
20	502472	Cylinder - bottom	1
19	502430	Cylinder - head	1
18	502426	Cylinder - house asm.	1
17	502309	Tube - protection	1
16	502295	Lockplate	2
15	502294	Bearing Heminex 3	2
14	502258	Blanking cover	1
13	502112	Lockplate	1
12	500601	O-ring	2
11	500600	O-ring	2
10	500570	Bushing	2
9	500432	Hex. socket set screw	2
8	500333	Flat countersunk head cap screws	2
7	500267	Hex. socket head cap screw	44
6	500261	Hex. socket head cap screw	4
5	500258	Hex. socket head cap screw	4
4	500250	Hex. socket head cap screw	4
3	500133	Bolts Hexagon	4
2	500068	Washer spring	4
1	500031	Nut Hexagon self-locking	2
POS	PARTNUMBER	PARTNAME	QT

Rotatable Combi Shear	Page	11	of	15
	Date	March 2010		
	Product type	DRC-25		
Flange GP bottom	Number	502478-02		

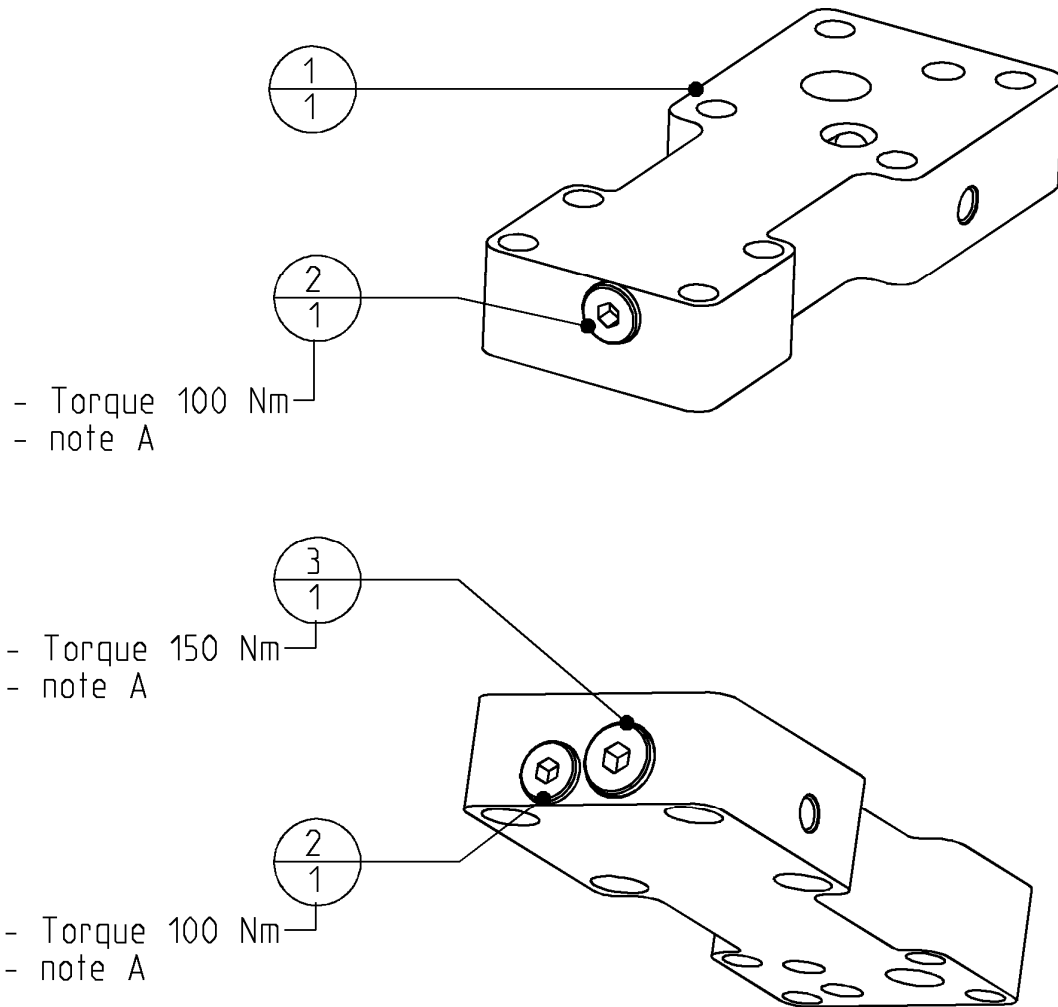

note A

- # Degrease threads with brake cleaner.
- # Rub in- and outside threads in with Cyberbound TT62 by using a brush.
- # Clean seal from plug during screwing in.
- # A drying time from the glue of at least 1 hour needs to be respected before it has any contact with oil.

3	290058185	Blanking end ISO 6149	1
2	290058184	Blanking end ISO 6149	2
1	502479	Flange - bottom	1
POS	PARTNUMBER	PARTNAME	QT

Rotatable Combi Shear	Page	12	of	15
	Date	March 2010		
	Product type	DRC-25		
Valve GP	Number	270057528-B		

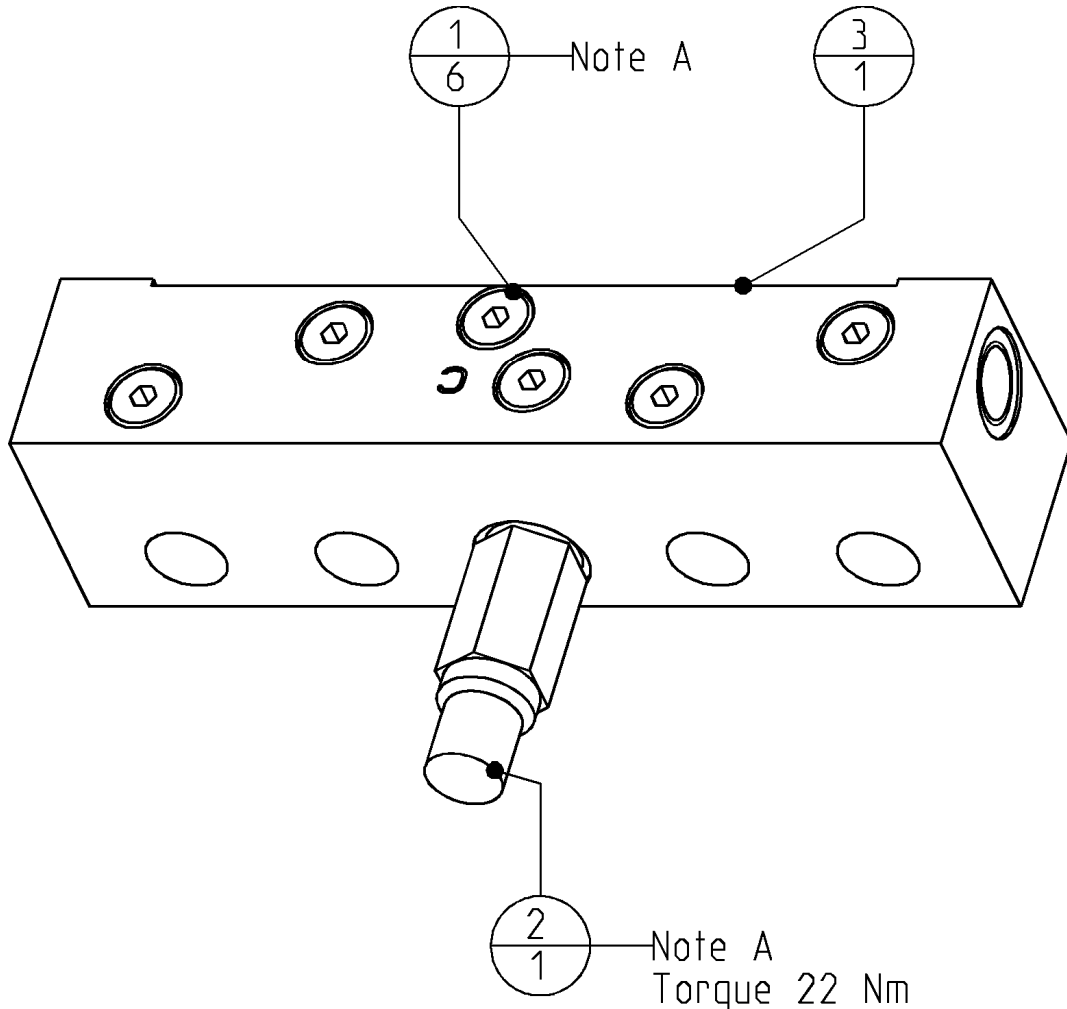

Note A

- # Degrease threads with brake cleaner.
- # Rub in- and outside threads in with Cyberbound TT62 by using a brush.
- # Clean seal from plug during screwing in.
- # A drying time from the glue of at least 1 hour needs to be respected before it has any contact with oil.

3	272057526	Baseplate	1
2	271059401	Cross-over relieve valve	1
1	500650	Blanking end	6
POS	PARTNUMBER	PARTNAME	QT

Rotatable Combi Shear

Page	13	of	15
Date	March 2010		
Product type	DRC-25		
Number	502286-01		

Swivel GP

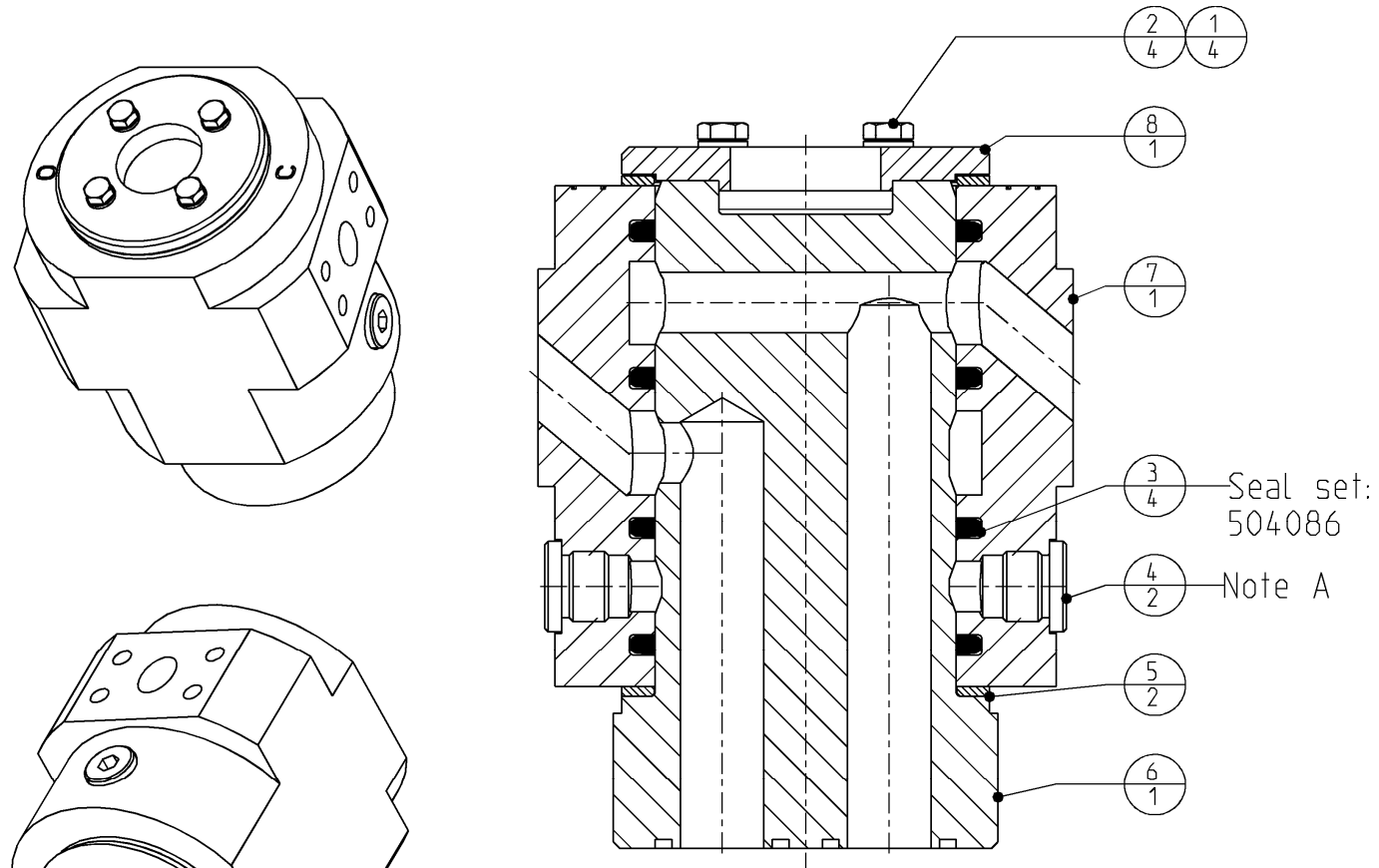

Note A

- # Degrease threads with brake cleaner.
- # Rub in- and outside threads in with Cyberbound TT62 by using a brush.
- # Clean seal from plug during screwing in.
- # A drying time from the glue of at least 1 hour needs to be respected before it has any contact with oil.

8	502289	Cover	1
7	502288	Housing	1
6	502287	Stator	1
5	500832	Axial ring	2
4	500652	Blanking end	2
3	500630	Seal - Roto Glyd Ring with Rotolock	4
2	500105	Bolts Hexagon	4
1	500066	Washer spring	4
POS	PARTNUMBER	PARTNAME	QT

Rotatable Combi Shear	Page	14	of	15
	Date	March 2010		
	Product type	DRC-25		
Bearing Housing	Number	402962-00		

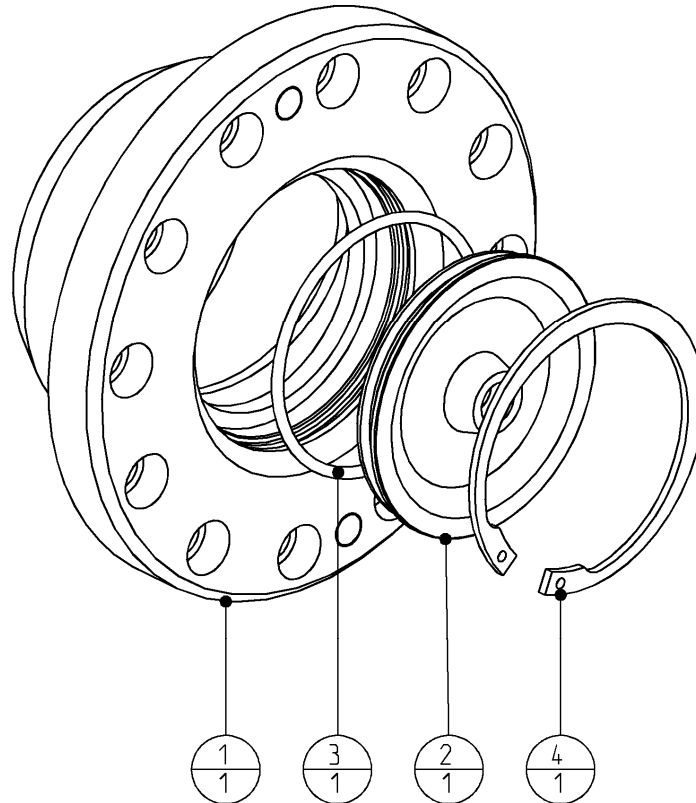

4	506024	Retainingring	1
3	504065	O-ring	1
2	402964	Cover	1
1	402963	Bearing housing	1
POS	PARTNUMBER	PARTNAME	QT

Rotatable Combi Shear	<i>Page</i>	15	<i>of</i>	15
	<i>Date</i>	March 2010		
	<i>Product type</i>	DRC-25		
Chemical lock	<i>Number</i>	n.a.		

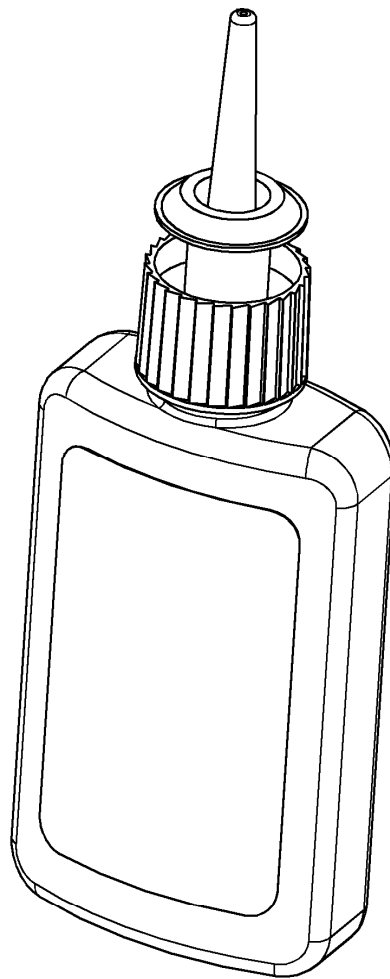

195050158	Cyberbond TT62 Pumpgel	1
506017	Loctite 638 Flacon 50 ml	1
506016	Loctite 270 Flacon 50 ml	1
PARTNUMBER	PARTNAME	QT