

# Parts book

Product type
DLP-25 Serie 1



Den Hoek 10  
5845 EL St. Anthonis  
the Netherlands  
Telephone +31 (0)485 442300  
Fax +31 (0)485 442120

[info@demarec.com](mailto:info@demarec.com)  
[www.demarec.com](http://www.demarec.com)



*Copyright Demolition and Recycling Equipment BV  
All rights strictly reserved.  
Reproductions to third parties in any form whatever is not permitted  
without written authority from the proprietor*

*Partsbook\_404460-00.doc*

# Rotatable Pulverizer

## Housing GP

Page	1	of	16
Date	September 2011		
Product type	DLP-25		
Number	DLP25L065AAA5 404460-00		

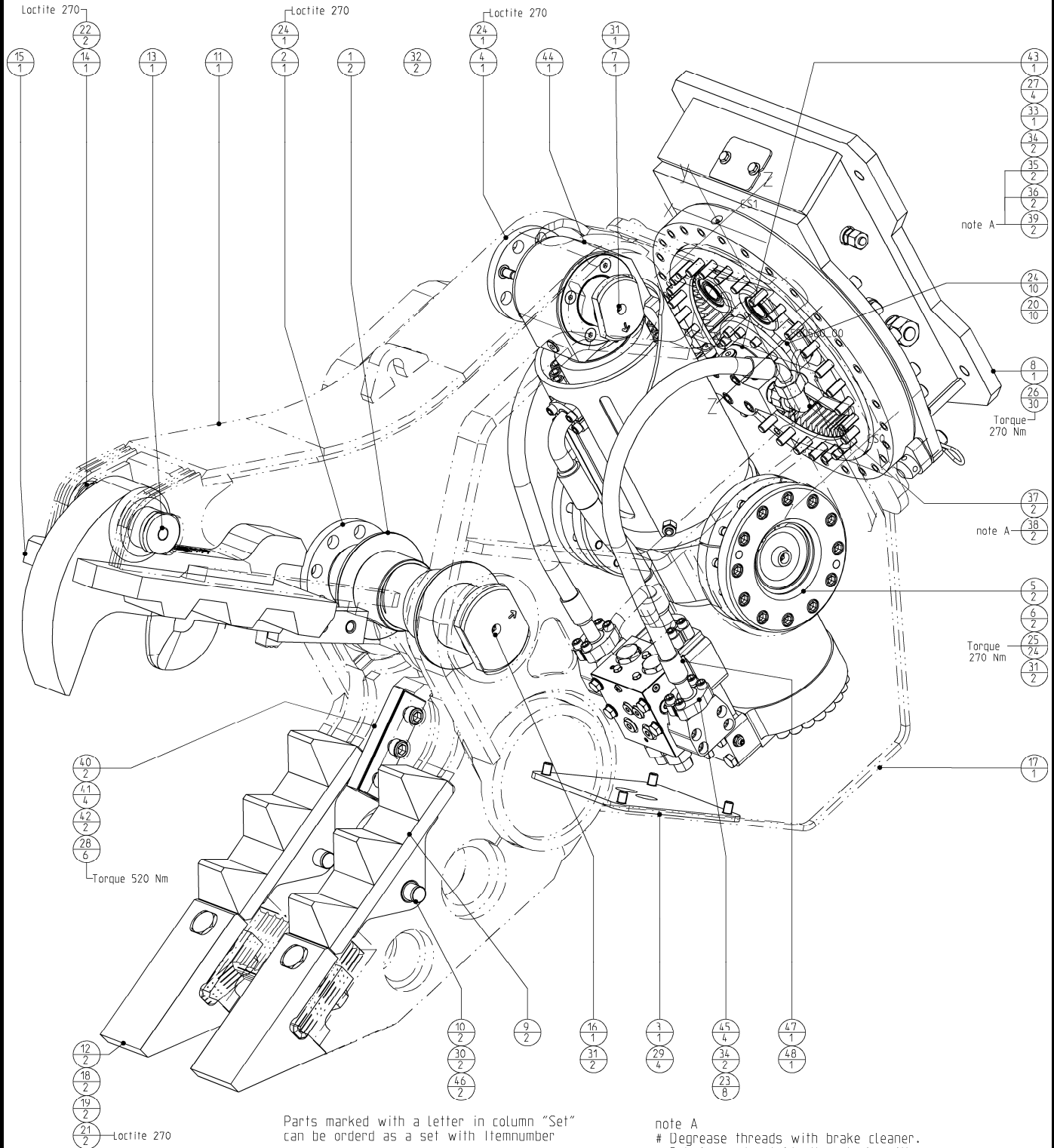

Parts marked with a letter in column "Set" can be ordered as a set with Itemnumber

Set	Wearpartset	Itemnumber
a	scraper teeth set	402847
b	teethplate	403794
c	tripod shroud set	402843
d	cuffingedge set	402848

- note A
- # Degrease threads with brake cleaner.
  - # Rub in- and outside threads in with Cyberbound TT62 by using a brush.
  - # Clean seal from plug during screwing in.
  - # A drying time from the glue of at least 1 hour needs to be respected before it has any contact with oil.

<b>Rotatable Pulverizer</b>	<i>Page</i>	<b>2</b>	<i>of</i>	<b>16</b>
	<i>Date</i>	<b>September 2011</b>		
	<i>Product type</i>	<b>DLP-25</b>		
<b>Housing GP</b>	<i>Number</i>	<b>DLP25L065AAA5 404460-00</b>		

						25	500265	Hex. socket head cap screw	24
						24	500258	Hex. socket head cap screw	12
	48	505089_VG04	Hydr. hose asm. 3/4"SAE 100R10	1		23	500250	Hex. socket head cap screw	8
	47	505089_VG03	Hydr. hose asm. 3/4"SAE 100R10	1		22	500247	Hex. socket head cap screw	2
c	46	504053	O-ring	2	a	21	500194	Bolts Hexagon	2
	45	503503	SAE split - flange	4		20	500069	Washer spring	10
	44	502530	Hydraulic Cylinder & Valve GP	1	a	19	500057	Washer HV	2
	43	501073	Swivel - flange	1	a	18	500008	Nut Hexagon	2
d	42	500952	Shim - straight	2		17	404462	Housing asm. machined	1
d	41	500951	Shim - straight	4		16	404458	Pin	1
d	40	500950	Shear - blade straight	2	b	15	403794	Teethplate P-25 series	1
	39	500740	Test-point	2		14	403067	Lock - cover	1
	38	500695	Male stud coupling	2		13	403066	Pin	1
	37	500675	Adjustable male stud elbow	2	a	12	403065	Tooth - Scraper	2
	36	500653	Blanking end	2		11	403038	Jaw - upper asm. machined	1
	35	500652	Blanking end	2	c	10	403023	Lock - pin	2
	34	500601	O-ring	4	c	9	403022	Shroud - Tripod	2
	33	500600	O-ring	1		8	402970	Rotatorhead GP (DRP-MQP)	1
	32	500572	Bushing	2		7	402967	Pin	1
	31	500560	Grease - nipple	5		6	402965	Ring	2
c	30	500559	Tension bush - outside	2		5	402962	Bearing - housing asm.	2
	29	500358	Flat countersunk head cap screws	4		4	401441	Locknut	1
d	28	500270	Hex. socket head cap screw	6		3	401416	Cover	1
	27	500268	Hex. socket head cap screw	4		2	401313	Locknut	1
	26	500266	Hex. socket head cap screw	30		1	401192	Spacer	2
					<b>SET</b>	<b>POS</b>	<b>PARTNUMBER</b>	<b>PARTNAME</b>	<b>QT</b>

# Rotatable Pulverizer

Page	<b>3</b>	of	<b>16</b>
Date	<b>September 2011</b>		
Product type	<b>DLP-25</b>		
Number	<b>402970-07</b>		

## Rotatorhead GP

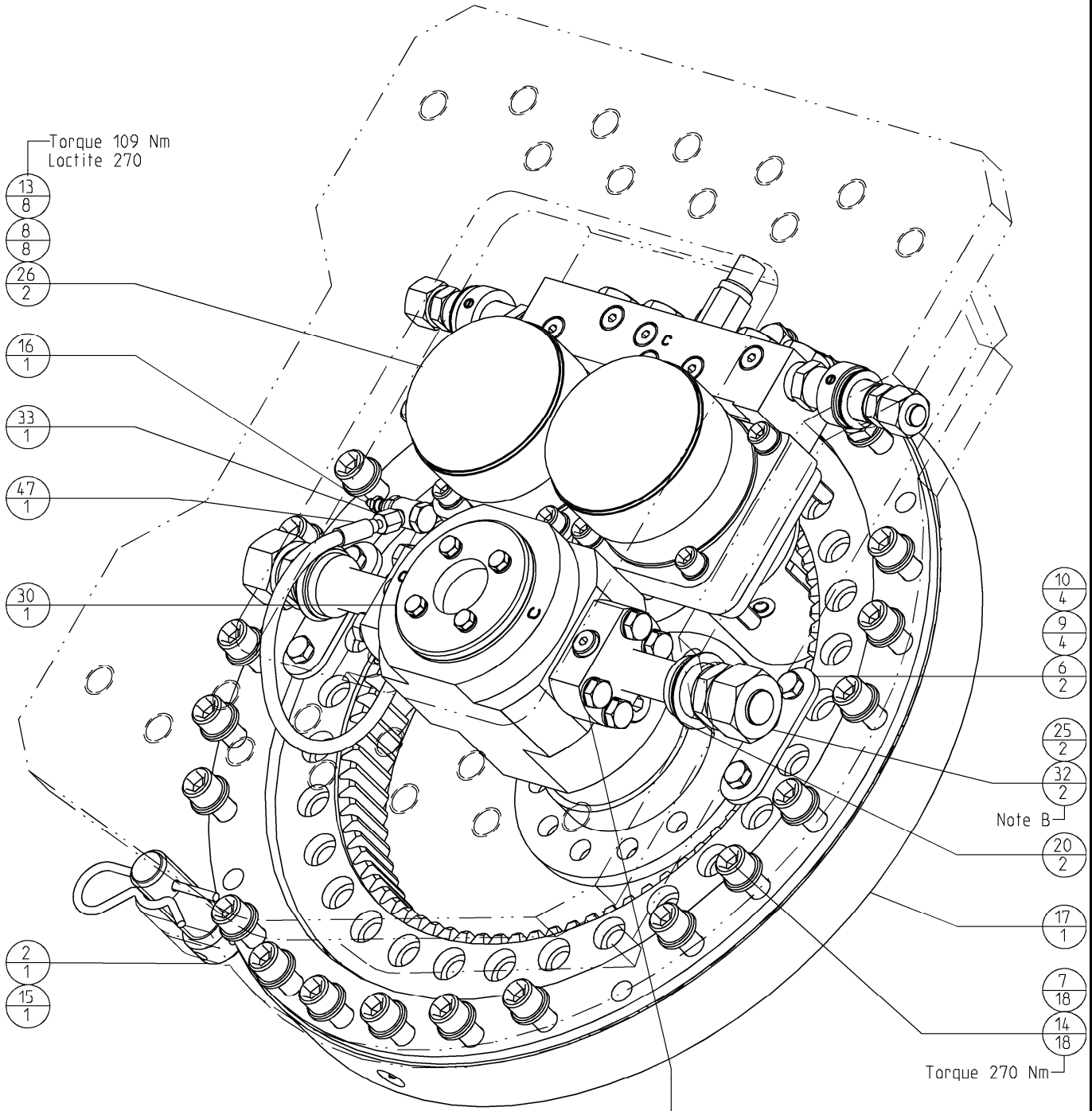

Note A  
Grind coupling on inside of motor flange flat.

Note B  
 # Degrease threads with brake cleaner.  
 # Rub in- and outside threads in with Cyberbound TT62 by using a brush.  
 # Clean seal from plug during screwing in.  
 # A drying time from the glue of at least 1 hour needs to be respected before it has any contact with oil.

1	19	21	8	11
2	2	2	8	8

Note B

# Rotatable Pulverizer

Page	<b>4</b>	of	<b>16</b>
Date	<b>September 2011</b>		
Product type	<b>DLP-25</b>		
Number	<b>402970-07</b>		

## Rotatorhead GP

- 38  
2
- 44  
1

Replaces:  
blanking end 503581

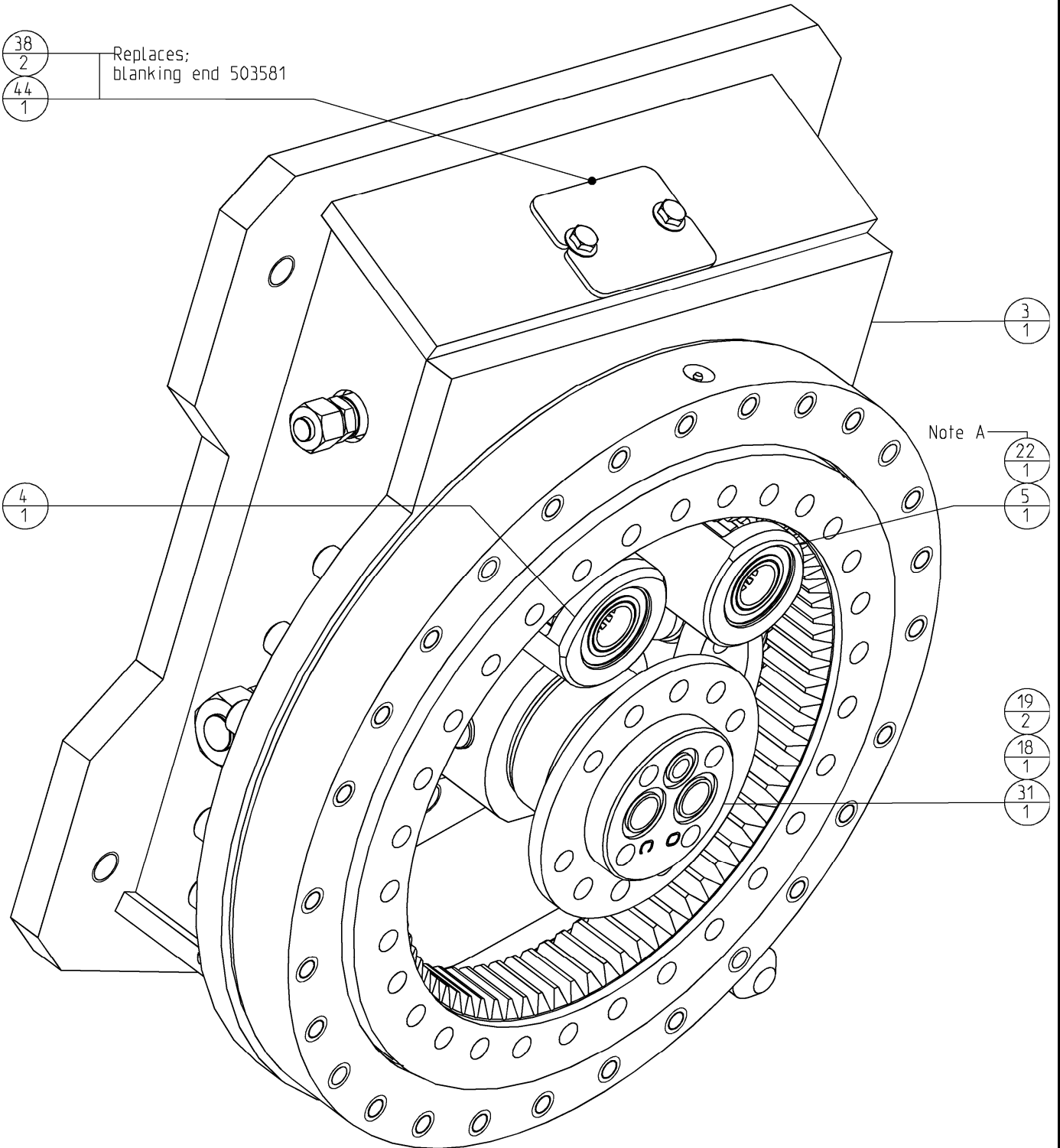

# Rotatable Pulverizer

Page	5	of	16
Date	September 2011		
Product type	DLP-25		
Number	402970-07		

## Rotatorhead GP

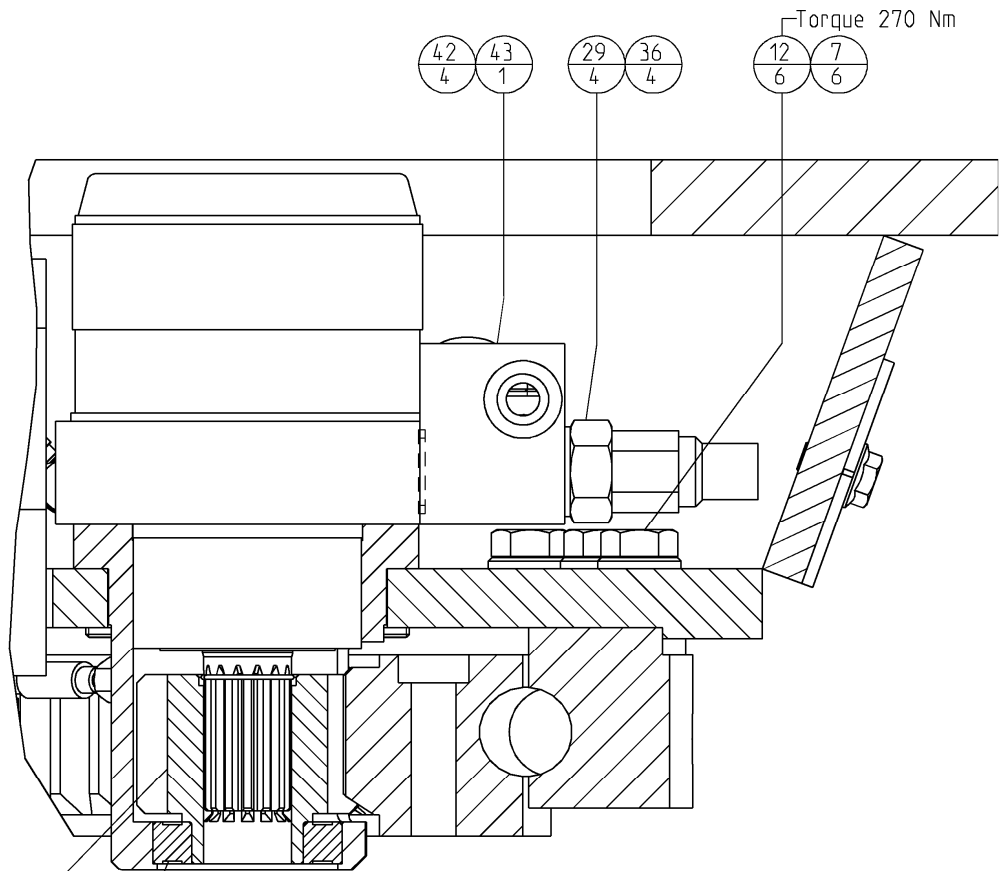

mount with fully greased teeth on motor

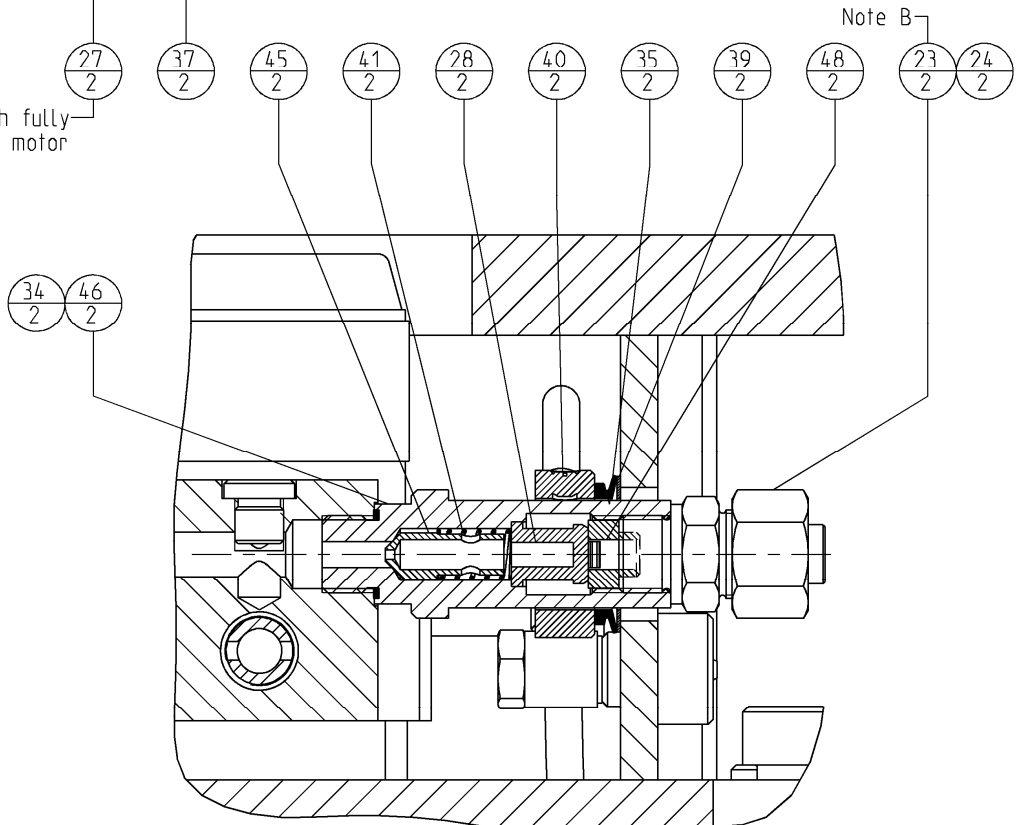

<b>Rotatable Pulverizer</b>	Page	<b>6</b>	of	<b>16</b>
	Date	<b>September 2011</b>		
	Product type	<b>DLP-25</b>		
<b>Rotatorhead GP</b>	Number	<b>402970-07</b>		

POS	PARTNUMBER	PARTNAME	QT	
	25	500947	Blanking plug	2
	24	500945	Blanking plug	2
48	773058645	Drossel - ring		2
47	296012594_VG02	Hydr. hose asm. 3/16" SAE 100R1AT		1
46	291058602	Sleeve G1/2"-G1/2"		2
45	273058601	Cone - valve + restriction		2
44	273013056	Cover		1
43	270057528	Valve GP		1
42	257057530	Quadseal		4
41	165050749	Spring		2
40	140000031	Ring - adjusting		2
39	122011550	Ring - shim		2
38	120013834	Bolts Hexagon - self locking		2
37	507002	Bearing - Ball		2
36	504081	Bonded seal		4
35	504068	Seal		2
34	504038	Seal G1/2'		2
33	503612	Banjo Coupling		1
32	503536	Male stud coupling		2
31	502330	Flange		1
30	502286	Swivel GP		1
29	502285	Banjo - bolt		4
28	502000	Filter		2
27	501058	Pinion		2
26	501057	Hydro - motor		2
	1	400214	Hydraulic flange - pipe	2
	2	400217	Lock-pin	1
	3	402971	Rotatorhead asm. machined	1
	4	402978	Motor flange & housing LH	1
	5	402979	Motor flange & housing RH	1
	6	402980	Cover	2
	7	500054	Washer HV	24
	8	500068	Washer spring	16
	9	500076	Washer spring	4
	10	500116	Bolts Hexagon	4
	11	500135	Bolts Hexagon	8
	12	500150	Bolts Hexagon	6
	13	500254	Hex. socket head cap screw	8
	14	500266	Hex. socket head cap screw	18
	15	500504-2	Locking pin (hair-pin)	1
	16	500560	Grease - nipple	1
	17	500590	Slewing Ring; Internal Gear	1
	18	500600	O-ring	1
	19	500601	O-ring	4
	20	500620	Seal	2
	21	500650	Blanking end	2
	22	500690	Male stud coupling	1
	23	500693	Male stud coupling	2

# Rotatable Pulverizer

Page **7** of **16**

Date **September 2011**

Product type **DLP-25**

## Cylinder & Valve GP

Number **502530-00**

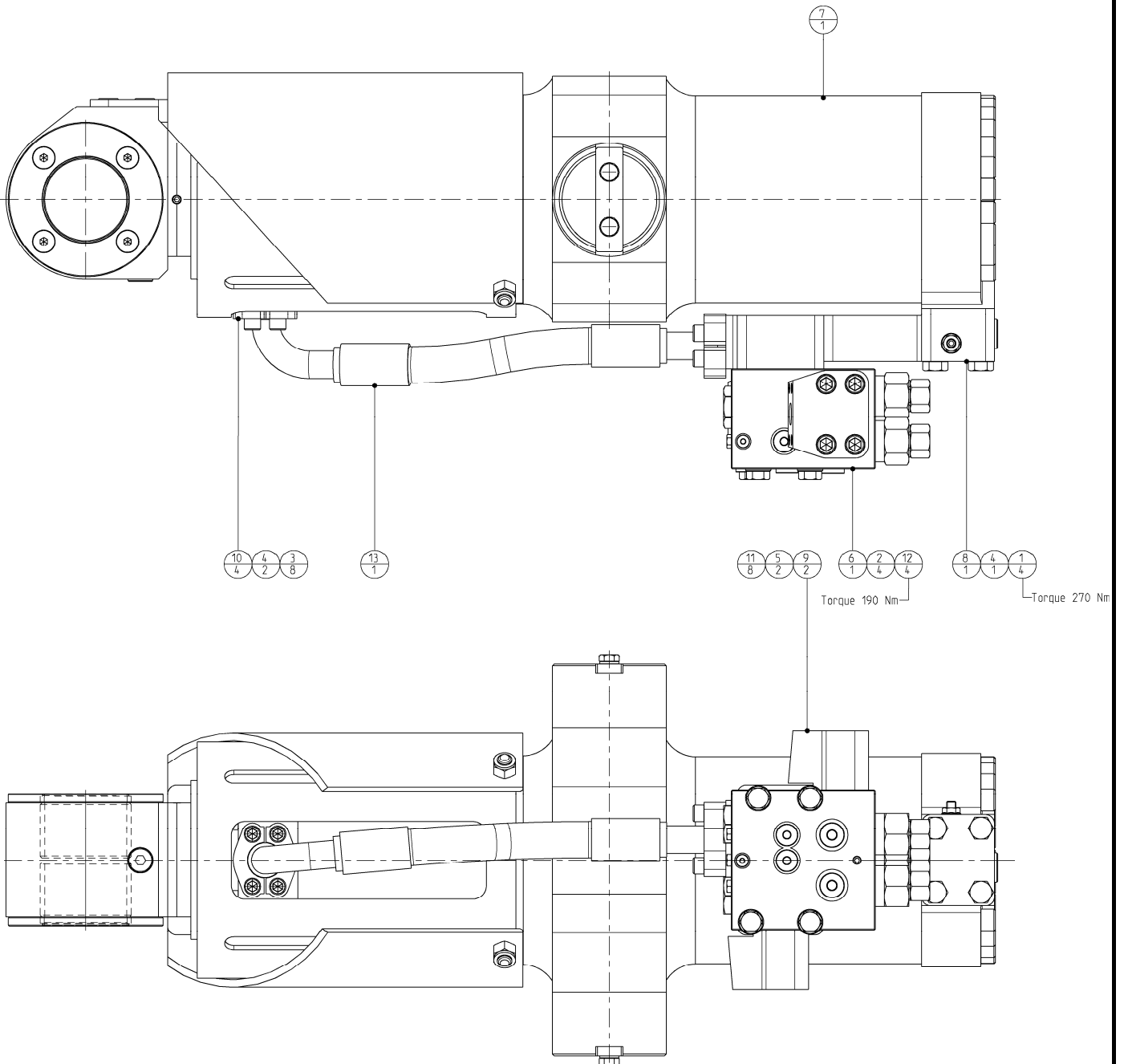



<b>Rotatable Pulverizer</b>	<i>Page</i>	<b>8</b>	<i>of</i>	<b>16</b>
	<i>Date</i>	<b>September 2011</b>		
	<i>Product type</i>	<b>DLP-25</b>		
<b>Cylinder &amp; Valve GP</b>	<i>Number</i>	<b>502530-00</b>		

13	505088_VG502530	Hydr. hose asm. 1" SAE 100R13	1
12	122000163	Washer normal	4
11	120060526	Hex. socket head cap screw	8
10	503503	SAE split - flange	4
9	502561	Flange 95°	2
8	502559	Flange - bottom GP	1
7	502531	Hydraulic Cylinder GP	1
6	500755	Overcentre valve	1
5	500603	O-ring	2
4	500601	O-ring	3
3	500250	Hex. socket head cap screw	8
2	500200	Bolts Hexagon	4
1	500149	Bolts Hexagon	4
<b>POS</b>	<b>PARTNUMBER</b>	<b>PARTNAME</b>	<b>QT</b>

# Rotatable Pulverizer

Page	9	of	16
Date	September 2011		
Product type	DLP-25		
Number	502531-00		

## Cylinder GP

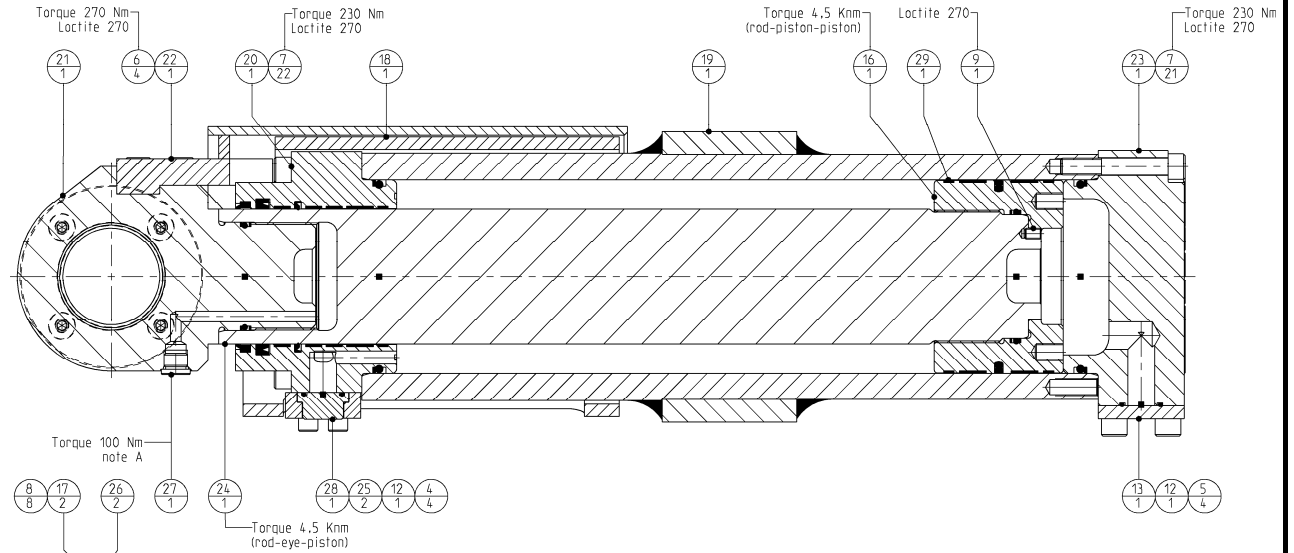

DETAIL A  
SCALE 4:5

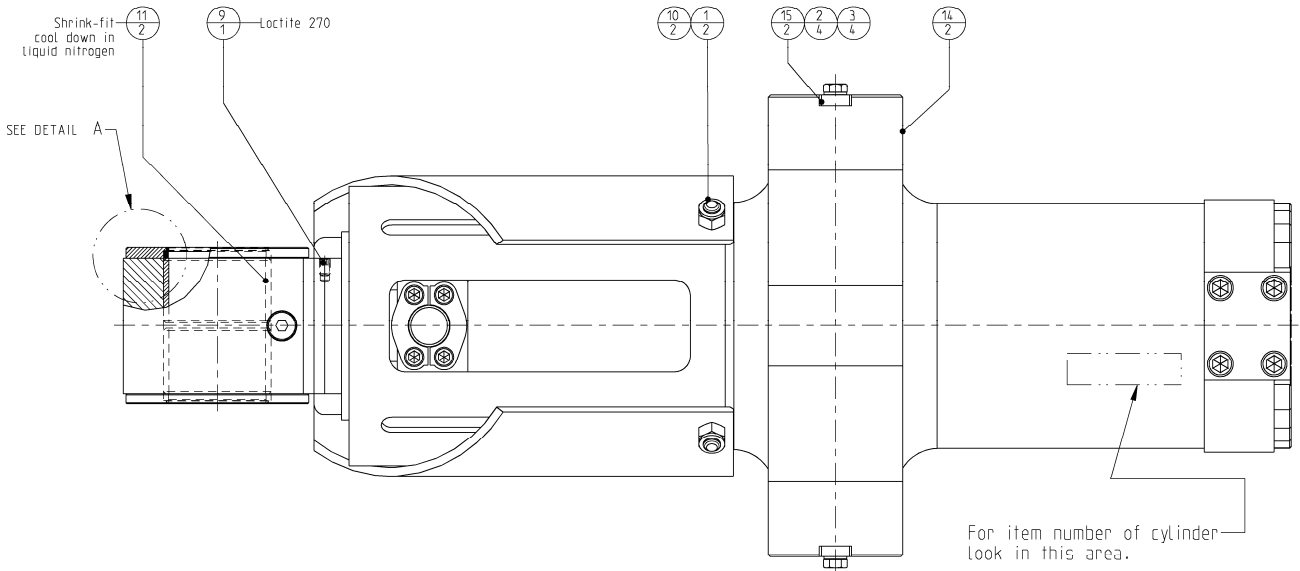

note A

- # Degrease threads with brake cleaner.
- # Rub in- and outside threads in with Cyberbound TT62 by using a brush.
- # Clean seal from plug during screwing in.
- # A drying time from the glue of at least 1 hour needs to be respected before it has any contact with oil.

<b>Rotatable Pulverizer</b>	<i>Page</i>	<b>10</b>	<i>of</i>	<b>16</b>
	<i>Date</i>	<b>September 2011</b>		
	<i>Product type</i>	<b>DLP-25</b>		
<b>Cylinder GP</b>	<i>Number</i>	<b>502531-00</b>		

29	502540_RM502530	Seal - set	1
28	291057570	SAE stop	1
27	290058184	Blanking end ISO 6149	1
26	504069	Scraper	2
25	503503	SAE split - flange	2
24	502533	Rod-tube	1
23	502532	Cylinder - bottom	1
22	502475	Protecion cap asm.	1
21	502474	Rod - eye	1
20	502430	Cylinder - head	1
19	502426	Cylinder - house asm.	1
18	502309	Tube - protection	1
17	502308	Spacer	2
16	502303	Piston	1
15	502295	Lockplate	2
14	502294	Bearing Heminex 3	2
13	502259	Blanking cover	1
12	500601	O-ring	2
11	500570	Bushing	2
10	500432	Hex. socket set screw	2
9	500417	Hex. socket set screw	2
8	500347	Flat countersunk head cap screws	8
7	500267	Hex. socket head cap screw	43
6	500261	Hex. socket head cap screw	4
5	500258	Hex. socket head cap screw	4
4	500250	Hex. socket head cap screw	4
3	500133	Bolts Hexagon	4
2	500068	Washer spring	4
1	500031	Nut Hexagon self-locking	2
<b>POS</b>	<b>PARTNUMBER</b>	<b>PARTNAME</b>	<b>QT</b>

# Rotatable Crusher

Page	<b>11</b>	of	<b>16</b>
Date	<b>September 2011</b>		
Product type	<b>DLP-25</b>		
Number	<b>500755-03</b>		

## Overcentre valve

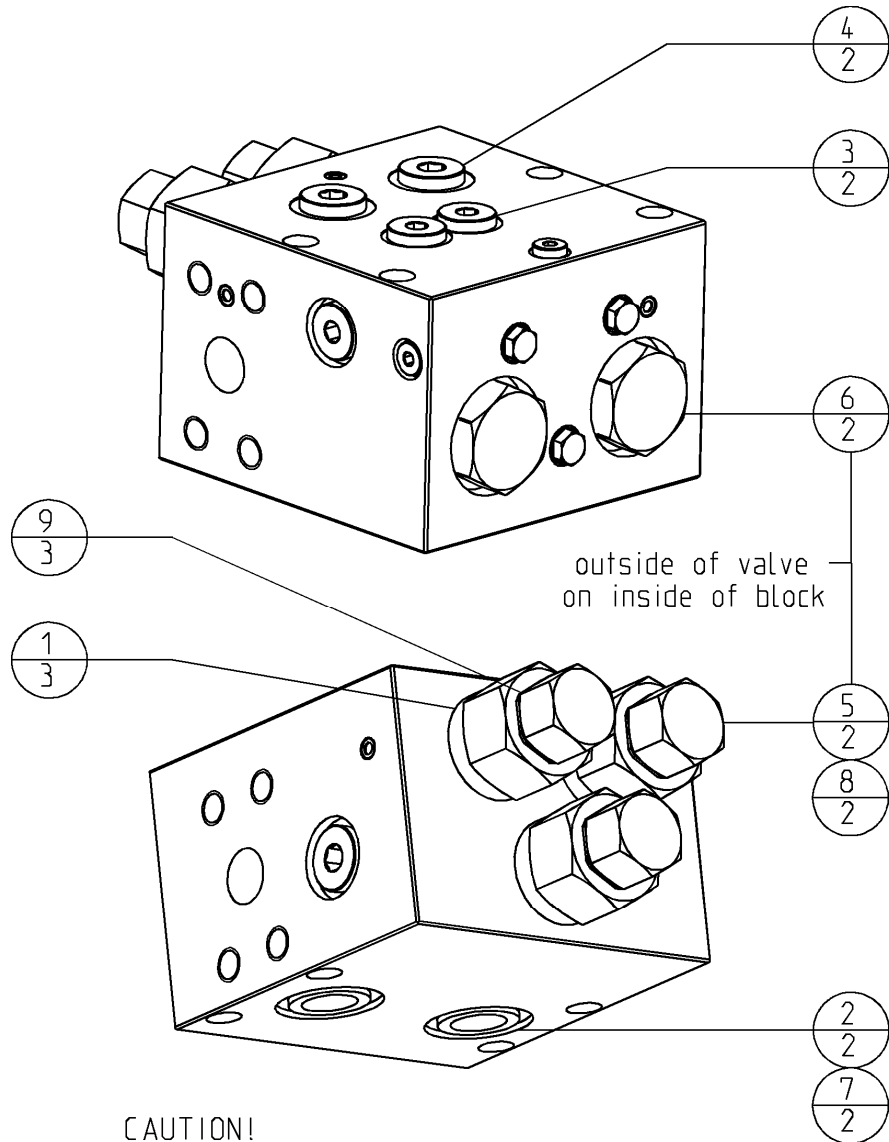

**CAUTION!**

Valve is equipped with high quality seals.  
All valves and blanking ends are mounted according special instructions.

For further information contact your dealer.

9	504034	Bonded seal	3
8	n.a.	Back-up ring	2
7	504026	Back-up ring	2
6	n.a.	O-ring	2
5	n.a.	O-ring	2
4	504083	O-ring	2
3	504082	O-ring	2
2	504017	O-ring	2
1	500601	O-ring	3
<b>POS</b>	<b>PARTNUMBER</b>	<b>PARTNAME</b>	<b>QT</b>
<b>sealset 504080-01</b>			

# Rotatable Pulverizer

Page	<b>12</b>	of	<b>16</b>
Date	<b>September 2011</b>		
Product type	<b>DLP-25</b>		
Number	<b>502559-00</b>		

## Flange GP bottom

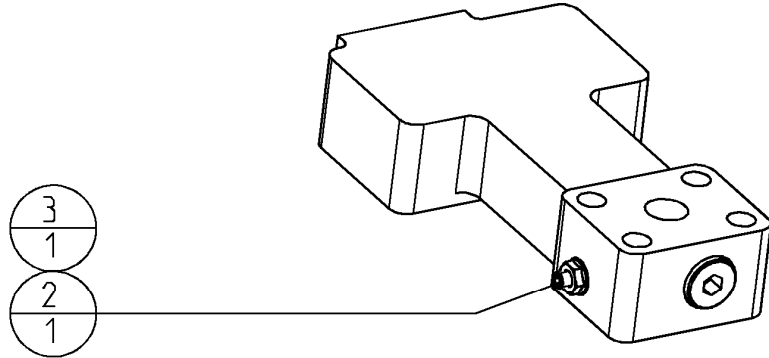

- Torque 150 Nm  
- note A

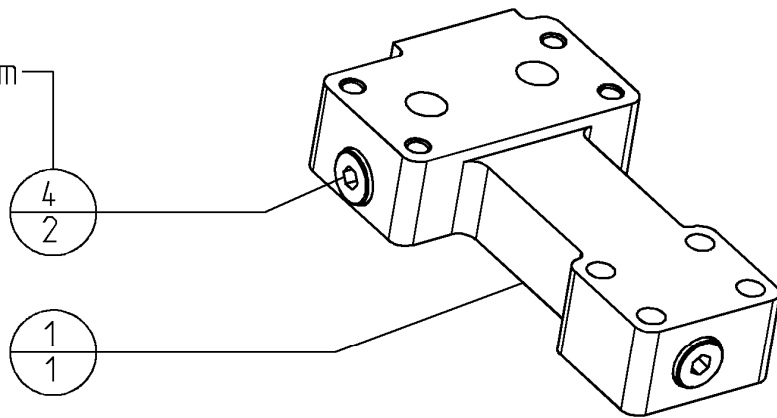

### note A

- # Degrease threads with brake cleaner.
- # Rub in- and outside threads in with Cyberbound TT62 by using a brush.
- # Clean seal from plug during screwing in.
- # A drying time from the glue of at least 1 hour needs to be respected before it has any contact with oil.

4	290058185	Blanking end ISO 6149	2
3	121060762	Nut Hexagon sealing	1
2	502562	Bleeding screw	1
1	502560	Flange - bottom	1
<b>POS</b>	<b>PARTNUMBER</b>	<b>PARTNAME</b>	<b>QT</b>

<b>Rotatable Pulverizer</b>	Page	<b>13</b>	of	<b>16</b>
	Date	<b>September 2011</b>		
	Product type	<b>DLP-25</b>		
<b>Valve GP</b>	Number	<b>270057528-B</b>		

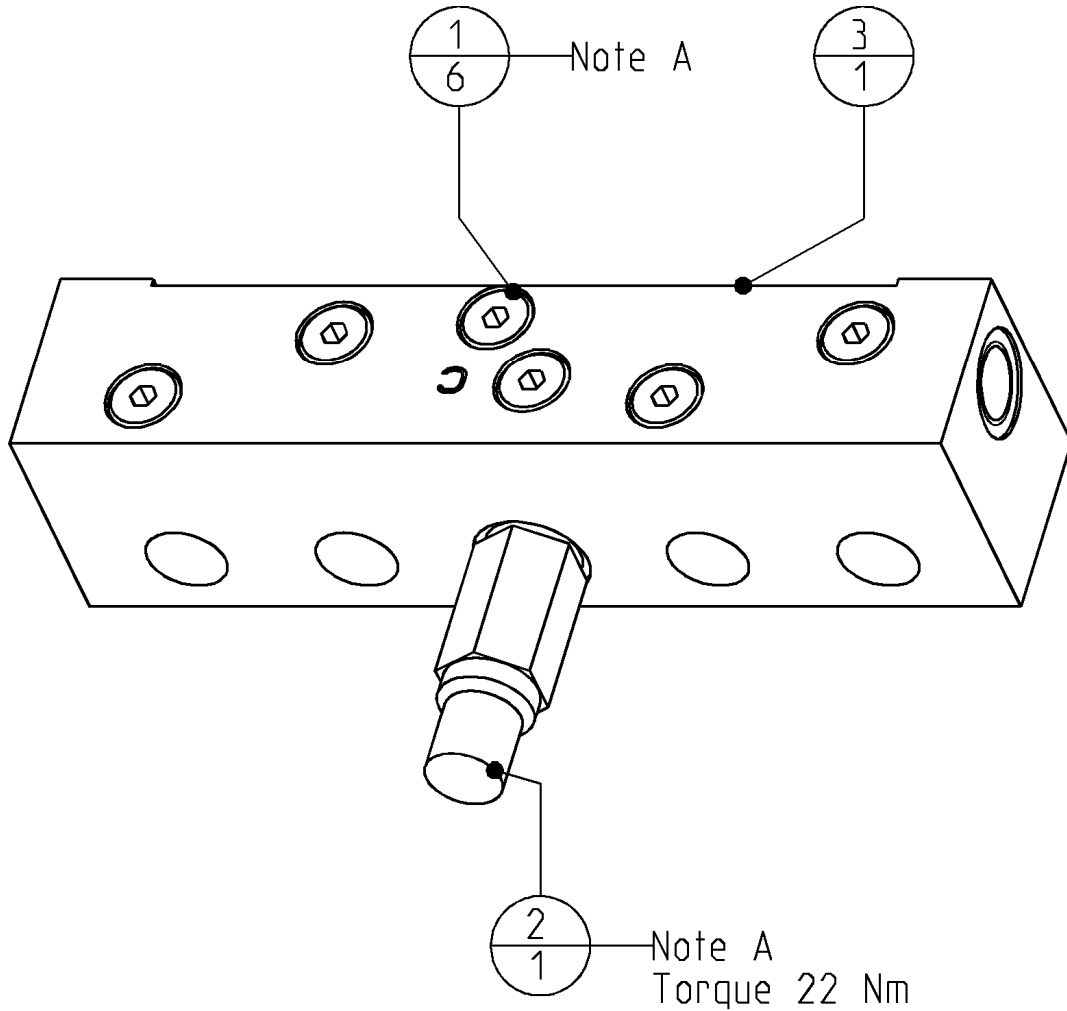

**Note A**

- # Degrease threads with brake cleaner.
- # Rub in- and outside threads in with Cyberbound TT62 by using a brush.
- # Clean seal from plug during screwing in.
- # A drying time from the glue of at least 1 hour needs to be respected before it has any contact with oil.

3	272057526	Baseplate	1
2	271059401	Cross-over relieve valve	1
1	500650	Blanking end	6
<b>POS</b>	<b>PARTNUMBER</b>	<b>PARTNAME</b>	<b>QT</b>

# Rotatable Pulverizer

Page	<b>14</b>	of	<b>16</b>
Date	<b>September 2011</b>		
Product type	<b>DLP-25</b>		
Number	<b>502286-01</b>		

## Swivel GP

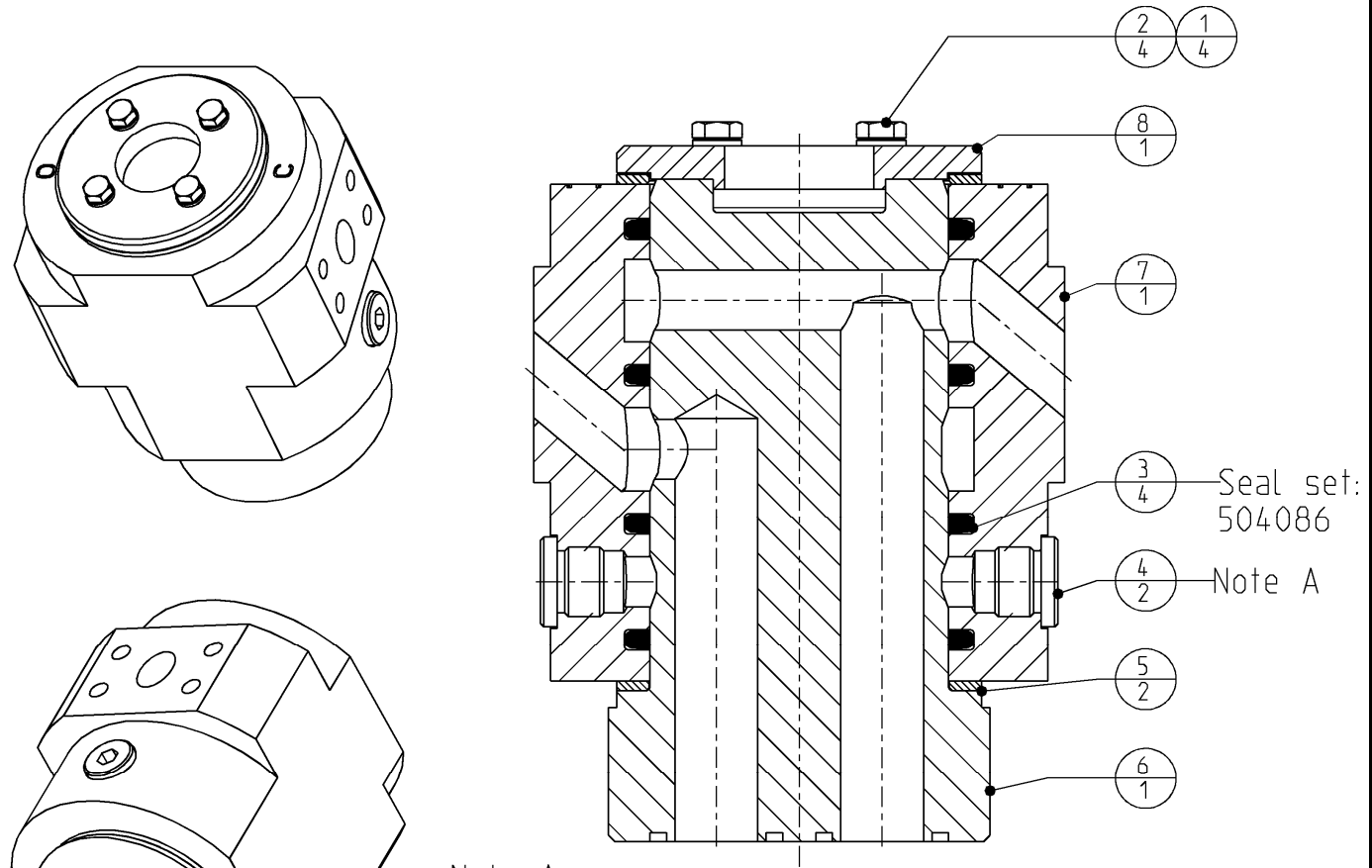

**Note A**

- # Degrease threads with brake cleaner.
- # Rub in- and outside threads in with Cyberbound TT62 by using a brush.
- # Clean seal from plug during screwing in.
- # A drying time from the glue of at least 1 hour needs to be respected before it has any contact with oil.

8	502289	Cover	1
7	502288	Housing	1
6	502287	Stator	1
5	500832	Axial ring	2
4	500652	Blanking end	2
3	500630	Seal - Roto Glyd Ring with Rotolock	4
2	500105	Bolts Hexagon	4
1	500066	Washer spring	4
<b>POS</b>	<b>PARTNUMBER</b>	<b>PARTNAME</b>	<b>QT</b>

<b>Rotatable Pulverizer</b>	Page	<b>15</b>	of	<b>16</b>
	Date	<b>September 2011</b>		
	Product type	<b>DLP-25</b>		
<b>Bearing Housing</b>	Number	<b>402962-00</b>		

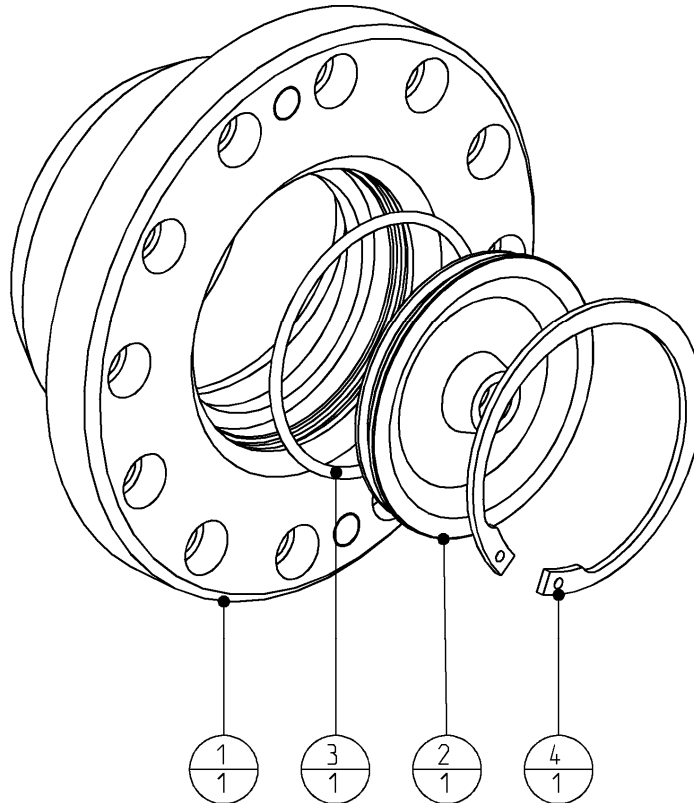

4	506024	Retainring	1
3	504065	O-ring	1
2	402964	Cover	1
1	402963	Bearing housing	1
<b>POS</b>	<b>PARTNUMBER</b>	<b>PARTNAME</b>	<b>QT</b>



<b>Rotatable Pulverizer</b>	<i>Page</i>	<b>16</b>	<i>of</i>	<b>16</b>
	<i>Date</i>	<b>September 2011</b>		
	<i>Product type</i>	<b>DLP-25</b>		
<b>Chemical lock</b>	<i>Number</i>	<b>n.a.</b>		

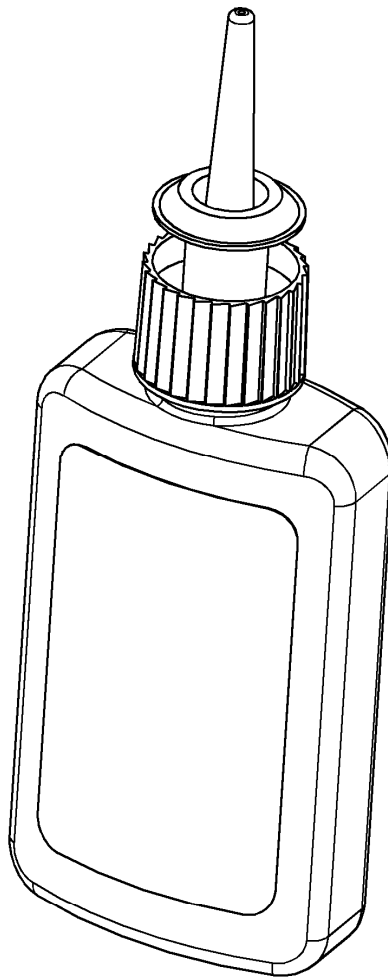

195050158	Cyberbond TT62 Pumpgel	1
506017	Loctite 638 Flacon 50 ml	1
506016	Loctite 270 Flacon 50 ml	1
<b>PARTNUMBER</b>	<b>PARTNAME</b>	<b>QT</b>