



Partsbook

for

Multi Quick Processor Combi jaw MQP-25-C

Product	Part Number
MQP-25-C Serie 2	MQP25C075BAA

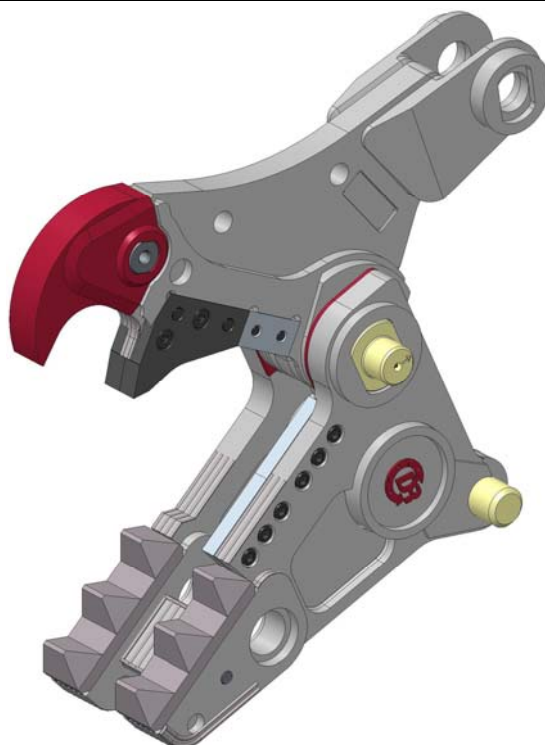

Partsbook_mqp25c075baa-a.docx

April 2015

Demarec Demolition and Recycling Equipment BV

Den Hoek 10, 5845 EL St. Anthonis, Netherlands

TEL.
FAX

+31 (0) 485 442300
+31 (0) 485 442120

INTERNET
E-MAIL

www.demarec.com
info@demarec.com

Multi Quick Processor

Page	1	of	4
Date	April 2015		
Product type	MQP-25-C		
Number	MQP25C075BAA-A		

Jaw GP

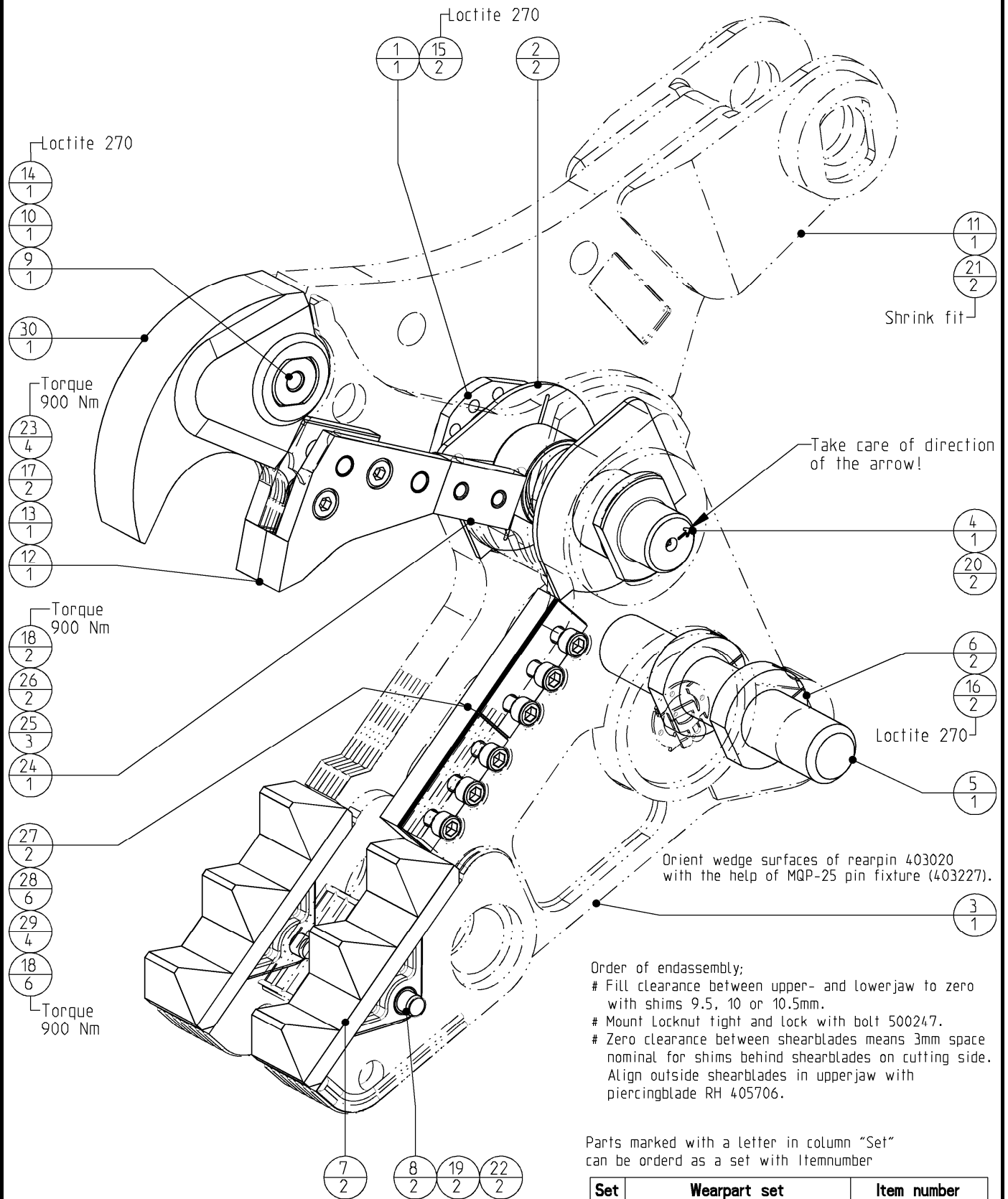

Set	Wearpart set	Item number
a	Tripod set	402843
b	Shearblade set	402844
c	Piercingblade set	405705
d	Rippertooth set (excl. pin)	402846

Multi Quick Processor	Page	2	of	4
	Date	April 2015		
	Product type	MQP-25-C		
Jaw GP	Number	MQP25C075BAA-A		

d	30	740057906	Rippertooth	1
b	29	508022	Shim - straight	4
b	28	508021	Shim - straight	6
b	27	508020	Shearblade - straight	2
b	26	508007	Shim - straight	2
b	25	508006	Shim - straight	3
b	24	508005	Shearblade - straight	1
c	23	506022	Shoulder bolt	4
a	22	504053	O-ring	2
	21	500572	Bushing	2
	20	500560	Grease - nipple	2
a	19	500559	Tension bush - outside	2
b	18	500283	Hex. socket head cap screw	8
c	17	500263	Hex. socket head cap screw	2
	16	500262	Hex. socket head cap screw	2
	15	500247	Hex. socket head cap screw	2
d	14	500144	Bolts Hexagon	1
c	13	405707	Piercingblade - LH	1
c	12	405706	Piercingblade - RH	1
	11	403631	Jaw - upper asm. machined	1
d	10	403030	Lock - cover	1
	9	403029	Lock - pin	1
a	8	403023	Lock - pin	2
a	7	403022	Tripod	2
	6	403021	Ring - clamp	2
	5	403020	Pin	1
	4	403019	Pin	1
	3	402991	Jaw - lower asm. machined	1
	2	402105	Spacer	2
	1	402051	Locknut M110x4	1
Set	POS	PARTNUMBER	PARTNAME	QT

Multi Quick Processor	Page	3	of	4
	Date	April 2015		
	Product type	MQP-25-C		
Additional parts	Number	n.a.		

Chemical lock

195050158	Cyberbond TT62 Pumpgel	1
506018	Loctite 480 Flacon 20 gr	1
506017	Loctite 638 Flacon 50 ml	1
506016	Loctite 270 Flacon 50 ml	1
PARTNUMBER	PARTNAME	QT

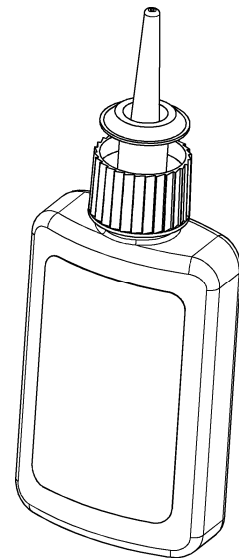

MAG welding wire

- for hard facing cutting blades
- 48-52 HRc

501237	Welding wire MAG; 1.8425, coil 15kg	1
PARTNUMBER	PARTNAME	QT

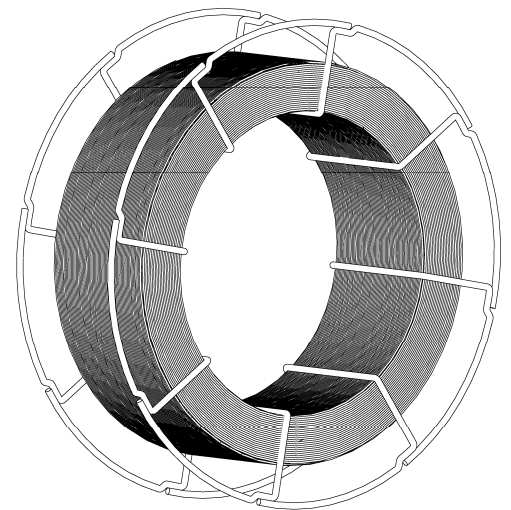

Welding electrodes

- for hard facing cutting blades
- 48-52 HRc

501238	Weld. electr.:1.8425, Ø 2.5mm, box 5kg	1
PARTNUMBER	PARTNAME	QT

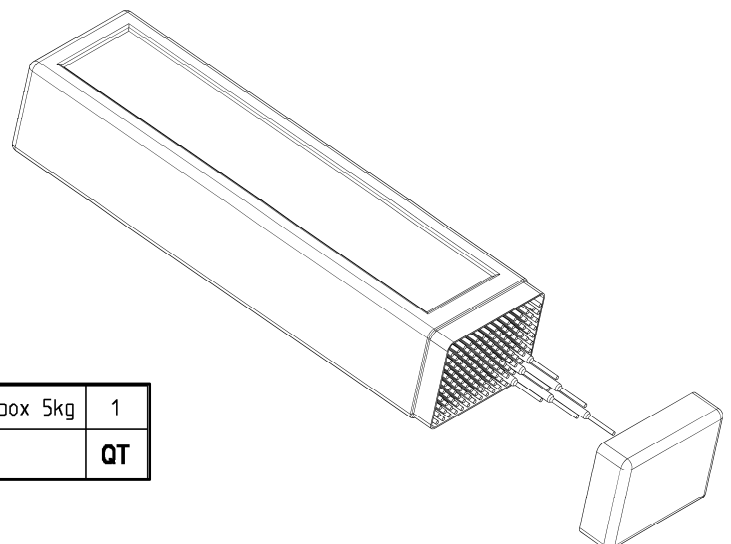

Multi Quick Processor	Page	4	of	4
	Date	April 2015		
	Product type	MQP-25-C		
Instructions	Number	n.a.		

Mounting instructions for Cyberbound TT 62

This instruction shall guarantee that all hydraulic fittings and cartridges will be mounted and glued in correctly.

Procedure:

Clean and degrease thoroughly all components with a special cleaner for anaerobic adhesives (e.g. Loctite cleaner 7063) or acetone.

Apply on the outside thread only a bead of Cyberbond TT62 pump gel to approx. 2/3 of the girth of the second thread for fittings up to a diameter of 20mm or to the entire girth for fittings with a diameter larger than 20mm.



Cyberbound
TT 62



Clean from adhesive residues pressed out from the bore hole after fitting.

ATTENTION. The sealings shall be free of adhesive residues!

Tighten fittings with given fastening torques.

Standard torque values for bolts (when not indicated)

Thread size	Torque (Nm) for quality		
	8.8	10.9	12.9
M8	22,5	32,4	38,7
M10	45,0	63,0	75,6
M12	77,4	109,0	131,0
M16	194,0	270,0	324,0
M20	369,0	522,0	630,0
M24	639,0	900,0	1080,0
M27	945,0	1305,0	1575,0
M30	1260,0	1800,0	2160,0



DEMAREC AND KINSHOFER WORLDWIDE

Netherlands:

Demarec

Demolition and Recycling Equipment BV

Den Hoek 10

5845 EL St. Anthonis

Netherlands

TEL. +31 (0) 485 442300

FAX +31 (0) 485 442120

Email:

info@demarec.com

United Kingdom:

Kinshofer UK Ltd.

4 Milton Industrial Court,

Horsfield Way, Bredbury

Stockport, Cheshire, SK6 2TA

United Kingdom

TEL. +44 (0) 161 - 406 7046

FAX +44 (0) 161 - 406 7014

Email:

sales@kinshofer.co.uk

France:

Kinshofer France S.A.R.L.

B.P. 20100

67213 Obernai Cedex

France

TEL. +33 (0) 388 39 55 00

FAX +33 (0) 388 79 06 75

Email:

info@kinshofer.fr

Czech Republic:

Kinshofer CZ s.r.o.

Cs. Legji 568

37810 Ceske Velenice

Czech Republic

TEL. +420 384 – 795 110

FAX +420 384 – 795 120

Headquarters:

Germany:

Kinshofer GmbH

Hauptstrasse 76

83666 Waakirchen

Germany

TEL. +49 (0) 8021 – 88 99 0

FAX +49 (0) 8021 – 88 99 37

Email:

info@kinshofer.com

North America:

Kinshofer North America

5040 Mainway Drive, Unit 11

Burlington, ON L7L 7G5

Canada

TEL. +1 (905) 335 2856

FAX +1 (905) 335 4529

Toll Free in Canada and USA:

TEL. 1-800-268-9525

Email:

sales-northamerica@kinshofer.com

Finland:

Kinshofer Aponox Oy

Terminaalitie 10

13430 Hämeenlinna

Finland

TEL. +358 (0)75 7540 200

FAX +358 (0)75 7540 210

Beijing:

Darda Kinshofer

Construction Machinery Co. Ltd.

Unit #306, Landmark Tower 2

8 Dongsanhuan Road

Beijing 100004

China

TEL. +86 (10) 6590 6422

FAX +86 (10) 6590 6423

Email:

info@darda.com.cn